

# Insulated Unit

for temperatures exceeding 430°F (221°C) to 700°F (371°C)

- Furnished as an attached unit. Disk's nameplate rating must be established at the cold face temperature of the insulation
- NOT available for TWO-WAY Disks or disks with ring or plate vacuum supports
- Insulated Units are supplied armored with required insulation and gaskets for service above 430°F (221°C) to 700°F (371°C). Standard armor is carbon steel, gaskets are compressed fiber, and insulation is spun alumina/silica. This insulation prohibits use with liquids and some corrosives. Other materials are available upon request
- Contact ZOOK for flow reduction factor when using Insulated Unit
- For temperatures exceeding 700°F (371°C) contact ZOOK

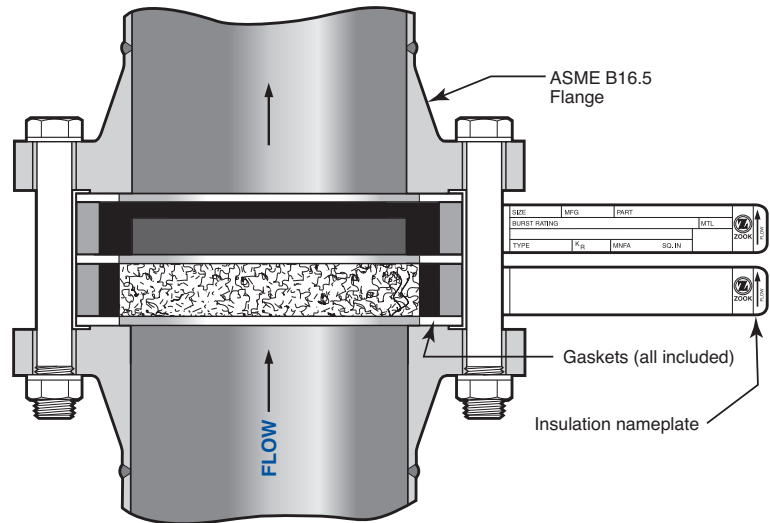
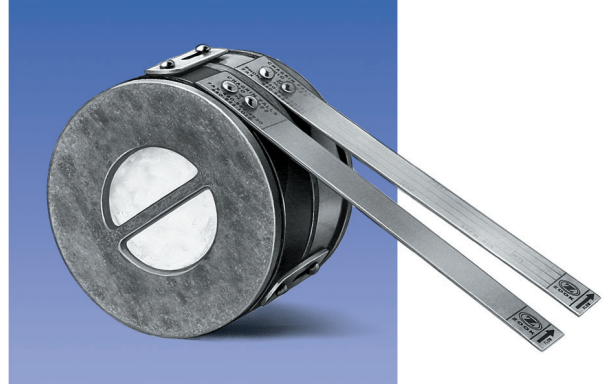

## Vacuum

Disks are self-supporting up to full vacuum at burst ratings of 25 psig and higher. At lower pressures, integral vacuum supports are available only for MONO Disks. External vacuum supports are available for DUPLEX Disks. Contact ZOOK for partial vacuum services.

## Dimensional Standards

Standard disks fit directly between ASME B16.5 Class 150 or 300 flanges with flat or raised faces. Flat ring gaskets are required and can be attached to the disk before shipment. Contact ZOOK for flange requirements other than ANSI.

## Capacity and Flow Resistance

Full bore opening at time of rupture is a consistent characteristic of ZOOK Disks and results in very low flow resistance values ( $K_F$ ). Refer to  $K_F$  values in tables provided for each disk type.

## Service Life

Indefinite service life is normal in static systems. Replacement is unnecessary at operating-pressure to burst-rating ratios to 90%. In cycling service, this ratio should be lowered.

## Burst Sensors

For remote and quick detection of a ruptured condition, ZOOK offers the ZENSOR™: Rupture disk and sensing element are integral parts of the electrical circuit to eliminate false readings. Model BA: An external re-usable and replaceable indicator. Specify Model BA-L for optional leak detection.

## Armor

Armor is available on any standard style, size and rating of graphite rupture disk. Standard material is Carbon Steel (316SS optional). Armor is required on the following:

- Disks for ASME B16.5 Class 300 flanges
- TWO-WAY Type Disks
- Disks rated for temperatures above 338°F (170°C), regardless of disk style or flange class
- Disks for ASME B16.5 Class 150 flanges. See table at right with the following sizes and burst ratings:

Sizes	Rated Over psig @ 72°F (22°C)
1/2" - 3"	150
4"	100
6" - 10"	75
12" - 24"	50

Where fire or blowdown temperatures exceeding 338°F (170°C) are design considerations, armor is required. Armored disks typically withstand the same conditions, i.e. blowdown temperatures, as the piping.

Disks not covered above are furnished unarmored unless armor is specifically ordered. Armor is highly recommended for:

- added safety
- greater reliability
- easier installation.

ZOOK service personnel are available 24 hours-a-day, 7 days-a-week, 365 days-a-year