



# Easy, safe, fire-resistant – STRAUB-FIRE-FENCE®

**NEW**



We currently have the following approvals:



The following approvals have been applied for:



**straub®**   
**the original**

an *O*Aliaxis company

**Specifications STRAUB-METAL-GRIP-FIRE-FENCE®**  
**Ø 30.0 – 219.1 mm**

Components / Materials	W1	W2	W4	W5 (on request)
Casing		1.4301 (V2A)	1.4301 (V2A)	
Screws		1.7220 <sup>o</sup>	1.4401	
U-bolts		1.0737, galvanized	1.4301	
Anchoring ring		1.4310	1.4310	
Strip insert (option)		1.4435 / PVDF	1.4435 / PVDF	
Fence		1.4401	1.4401	
Retardent		intumescent polymer	intumescent polymer	
Sealing sleeve <b>EPDM</b>		Temp.: -30°C up to +100°C Medium: all qualities of water, waste water, air, solids and chemical products		
Sealing sleeve <b>NBR</b>		Temp.: -20°C up to +80°C Medium: water, gas, oil, fuel and other hydrocarbons		

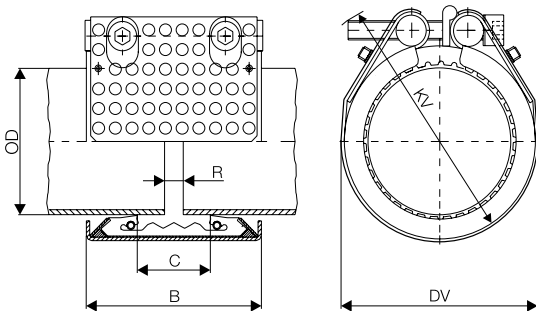

Pipe OD (mm)	Clamping range (mm)	Nominal- pressure PN (bar)	Working- pressure PS (bar)	Dimension				Setting gap between pipe ends R		Locking bolts		
				B (mm)	C (mm)	DV (mm)	KV (mm)	Without Steel strip insert (mm)	With	Torque rate (Nm)	Allen head (mm)	Thread M ...
30.0	29.5 – 30.5	16.0	67	56/77	18	57	75	5	5	10	6	8
33.7	33.2 – 34.2	16.0	62	56/77	18	62	80	5	5	10	6	8
38.0	37.5 – 38.5	16.0	58	71	19	68	95	5	5 – 10	15	6	8
42.4	41.9 – 42.9	16.0	53	71	20	72	95	5	5 – 10	15	6	8
44.5	44.0 – 45.0	16.0	48	71	20	74	100	5	5 – 10	15	6	8
48.3	47.8 – 48.8	16.0	44	71	20	78	100	5	5 – 10	15	6	8
54.0	53.5 – 54.5	16.0	39	87	38	84	105	5	5 – 15	20	6	8
57.0	56.4 – 57.6	16.0	37	87	32	87	110	5 – 10	5 – 25	20	6	8
60.3	59.7 – 60.9	16.0	37	87	32	92	115	5 – 10	5 – 25	20	6	8
63.5	62.9 – 64.1	16.0	37	93	32	94	119	5 – 10	5 – 25	20	8	8
76.1	75.3 – 76.9	16.0	56	110	39	110	135	5 – 10	5 – 25	35	8	10
84.0	83.2 – 84.8	16.0	45	110	39	122	145	5 – 10	5 – 25	35	8	10
88.9	88.0 – 89.8	16.0	41	110	39	127	150	5 – 10	5 – 25	35	8	10
104.0	103.0 – 105.0	16.0	37	110	39	143	165	5 – 10	5 – 25	35	8	10
108.0	106.9 – 109.1	16.0	35	110	39	143	165	5 – 10	5 – 25	35	8	10
114.3	113.2 – 115.4	16.0	34	110	39	149	170	5 – 10	5 – 25	35	8	10
129.0	127.7 – 130.3	16.0	33	124	51	170	195	5 – 15	5 – 30	60	10	12
133.0	131.7 – 134.3	16.0	33	124	43	170	195	5 – 15	5 – 25	60	10	12
139.7	138.3 – 141.1	16.0	32	125	43	178	205	5 – 15	5 – 25	60	10	12
154.0	152.5 – 155.5	16.0	32	125	51	196	220	5 – 15	5 – 30	60	10	12
159.0	157.4 – 160.6	16.0	31	125	43	197	220	5 – 15	5 – 25	60	10	12
168.3	166.6 – 170.0	16.0	29	125	43	210	235	5 – 15	5 – 25	60	10	12
219.1	216.9 – 221.3	16.0	26	166	60	269	300	5 – 15	5 – 35	100	14	16

**Legend** W1 – W5 according to DIN Standard 86128 (ASTM F1476 / F1548, ISO/NP-15837 / 15838)  
 PN: Nominal pressure includes four times safety factor for applications that require authorization of classification societies like for Ship building (e.g. ABS, DNV, LR, etc.)  
 PS: Working pressure for industrial applications  
<sup>o</sup> Property class 12.9, Dacromet 500 (zinc-chromate with integrated lubricant)

- Remarks:**
- Follow fitting / disassembly instructions.
  - **Strip inserts** are required when the gap between the pipe ends is excessive, in presence of swelling, at vacuum/depression (suction line), or external pressure.  
Strip inserts are available, under separate order, at additional costs.
  - **Test pressure** = 1.5 x PN / PS.
  - According to IACS 2007 and ISO 19921:2005E and 19922:2005E
  - Other sizes on request
  - Other rubbers on request (HNBR, Viton)

**Specifications STRAUB-GRIP-L-FIRE-FENCE®**  
**Ø 26.9 – 219.1 mm**

Components / Materials	W5
Casing	1.4571
Screws	1.4401
U-bolts	1.4571
Anchoring ring	1.4310
Strip insert (option)	1.4435
Fence	1.4401
Retardent	intumescent polymer
Sealing sleeve	Temp.: -20°C up to +80°C
<b>EPDM</b>	Medium: all qualities of water, waste water, air, solids and chemical products
Sealing sleeve	Temp.: -20°C up to +80°C
<b>NBR</b>	Medium: water, gas, oil, fuel and other hydrocarbons

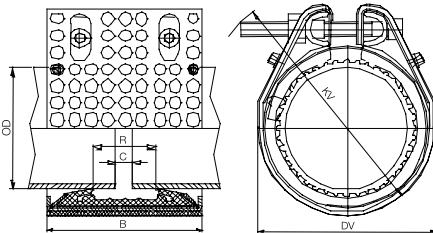

Pipe OD (mm)	Clamping range (mm)	Nominal- pressure PN (bar)	Working- pressure PS (bar)	Dimension				Setting gap between pipe ends R		Locking bolts		
				B (mm)	C (mm)	Braced		Without	With	Torque rate (Nm)	Allen head (mm)	Thread M ...
DV (mm)	KV (mm)	Steel strip insert (mm)										
26.9	26.4 – 27.4	16.0	46	56	19	53	75	5	5	7.5	5	6
30.0	29.5 – 30.5	16.0	42	56	17	57	80	5	5	7.5	5	6
33.7	33.2 – 34.2	16.0	38	56	17	61	80	5	5	7.5	5	6
38.0	37.5 – 38.5	16.0	33	71	25	67	95	5	5 – 10	15	6	8
42.4	41.9 – 42.9	16.0	30	71	25	72	100	5	5 – 10	15	6	8
44.5	44.0 – 45.0	16.0	33	71	25	74	100	5	5 – 10	15	6	8
48.3	47.8 – 48.8	16.0	30	71	25	77	105	5	5 – 10	15	6	8
54.0	53.5 – 54.5	16.0	20	86	37	86	110	5 – 10	5 – 15	15	6	8
57.0	56.4 – 57.6	16.0	18	86	37	86	110	5 – 10	5 – 15	15	6	8
60.3	59.7 – 60.9	16.0	22	86	37	89	115	5 – 10	5 – 15	15	6	8
66.6	64.9 – 67.3	16.0	34	111	35	97	131	5 – 10	5 – 20	20	6	8
70.0	68.9 – 70.7	16.0	32	111	36	102	136	5 – 10	5 – 20	20	6	8
73.0	72.3 – 73.7	16.0	31	111	41	106	147	5 – 10	5 – 25	20	6	8
76.1	75.3 – 76.9	16.0	31	111	41	108	147	5 – 10	5 – 25	20	6	8
79.5	78.7 – 80.3	16.0	28	111	35	110	147	5 – 10	5 – 25	20	6	8
84.0	83.2 – 84.8	16.0	26	111	35	122	157	5 – 10	5 – 25	20	6	8
88.9	88.0 – 89.8	16.0	22	111	41	121	162	5 – 10	5 – 25	20	6	8
100.6	99.6 – 102.6	16.0	22	111	35	139	177	5 – 10	5 – 25	25	6	8
101.6	100.6 – 102.6	16.0	22	111	35	140	177	5 – 10	5 – 25	25	6	8
104.0	103.0 – 105.0	16.0	22	111	35	142	177	5 – 10	5 – 25	25	6	8
104.8	103.8 – 105.8	16.0	22	111	35	143	177	5 – 10	5 – 25	25	6	8
108.0	106.9 – 109.1	16.0	21	111	41	140	177	5 – 10	5 – 25	25	6	8
114.3	113.2 – 115.4	16.0	16	111	41	146	182	5 – 10	5 – 25	25	6	8
127.0	125.7 – 128.3	16.0	19	126	54	161	200	5 – 10	5 – 30	40	8	10
129.0	127.7 – 130.3	16.0	19	126	54	163	200	5 – 10	5 – 30	40	8	10
130.2	128.9 – 131.5	16.0	19	126	54	164	205	5 – 10	5 – 30	40	8	10
133.0	131.7 – 134.3	16.0	19	126	54	167	205	5 – 10	5 – 30	40	8	10
139.7	138.3 – 141.1	16.0	16	126	54	174	215	5 – 10	5 – 30	40	8	10
141.3	139.9 – 142.7	16.0	16	126	54	176	215	5 – 10	5 – 30	40	8	10
154.0	152.5 – 155.5	13.0	16	126	48	194	230	5 – 10	5 – 30	40	8	10
159.0	157.4 – 160.6	13.0	16	126	54	193	230	5 – 10	5 – 30	40	8	10
168.3	166.6 – 170.0	13.0	16	126	54	202	235	5 – 10	5 – 30	40	8	10
219.1	216.9 – 221.3	10.0	16	158	80	260	300	5 – 10	5 – 30	60	10	12

**Legend** W1 – W5 according to DIN Standard 86128 (ASTM F1476 / F1548, ISO/NP-15837 / 15838)  
 PN: Nominal pressure includes four times safety factor for applications that require authorization of classification societies like for Ship building (e.g. ABS, DNV, LR, etc.)  
 PS: Working pressure for industrial applications

**Remarks:**

- OD 26.9 – 60.3 with one screw
- Follow fitting / disassembly instructions.
- **Strip inserts** are required when the gap between the pipe ends is excessive, in presence of swelling, at vacuum/depression (suction line), or external pressure.  
 Strip inserts are available, under separate order, at additional costs.
- **Test pressure** = 1.5 x PN / PS.
- According to IACS 2007 and ISO 19921:2005E and 19922:2005E
- Other sizes on request
- Other rubbers on request (HNBR, Viton)



## STRAUB-FIRE-FENCE®

### THE FIRE RESISTANT COUPLING For use wherever fire protection is required by law.

The STRAUB FIRE-FENCE combines functional design with latest technologies. The coupler is based on the reliable and well proven STRAUB coupling system and fulfils IMO (International Maritime Organisation) and IACS (International Association of Classification Societies) requirements alike, which have been in force since 1.1.2007.

Even with its flame protection, the coupling is space saving, shows significantly improved crush resistance and, thanks to the innovative design, is also lighter. The new STRAUB-FIRE-FENCE impresses with a modern, patented construction method, while at the same time retaining the well tested characteristics of STRAUB couplings.

Functionality: In the event of a fire, the intumescent\* fire protection coating expands, protectively enclosing the coupling. During this process, the coupling retains its full operational capability – without any limitations.

\* Under the influence of heat, intumescent materials increase in volume and decrease in density, i.e. the material expands. This produces an isolating heat shield which protects the assembly part.



*We reserve the right to make technical modifications.*

STRAUB-coupling

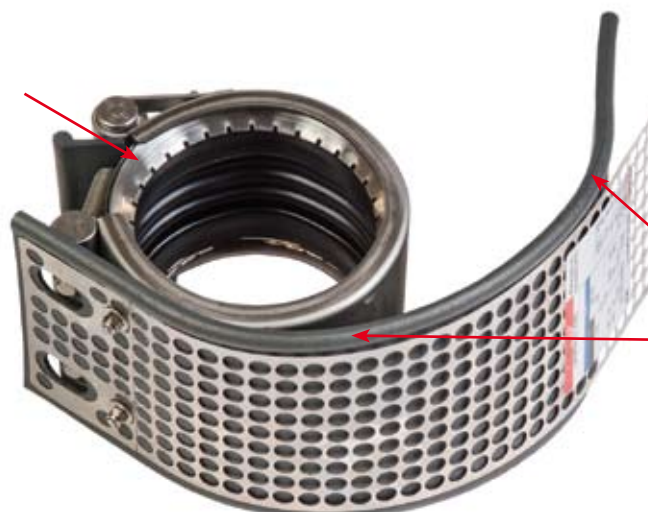

Protective  
metal layer

Intumescent  
polymer profile



Straub Werke AG, Rohrverbindungen, Straubstrasse 13, 7323 Wangs, Switzerland  
 Tel. +41 81 725 41 00, Fax +41 81 725 41 01, www.straub.ch, straub@straub.ch