



MECAFRANCE



Ball Valves
Product Overview





MECAFRANCE



MECAFRANCE has been recognized as a world class manufacturer of high quality and an innovative range of ball valves, which are used in the major process industries of the world

Experience and Reputation

With 50 years of valve manufacturing experience, MECAFRANCE has developed a reputation for high quality, dependable valves.

Totally Integrated Manufacturing Facility

MECAFRANCE ball valves are renowned for lasting, dependable service. Each valve is precision manufactured from foundry casting or forgings to final assembly.

Total quality control for every component is maintained from start to finish.

Dependable Quality Products and Performance

In addition, unique design features add to the lifetime expectation and performance of MECAFRANCE ball valves.

Quality Assurance (ISO 9001: 2000)

MECAFRANCE fully complies with the global ISO 9001: 2000 quality system requirements, one of the first major ball valve manufacturers to do so. This achievement is a confirmation of the many years of commitment MECAFRANCE has put forth towards product quality.

R&D

MECAFRANCE has an elaborated engineering and R&D department dedicated to the design, development and upgrading of valves and accessories. They have the help of modern and state of the art tools such as CAD and 3D modeling.

Added Value

We add value to the supply chain through reliable logistics and IT systems, investment in inventory, repair and after sales service.

Most important of all, our dedication, technical capabilities and service are the senses of accomplishment that come with customer satisfaction and a job well done.

3 Piece ball valves

Series RA, ISO mounted valves



- Integrated ISO top flange for easy automation
 - Cast and forged body materials
 - Stainless steel, carbon steel
 - Full bore and reduced bore
 - 'Swing-out' center part for easy seat and gasket replacements
 - Butt weld, socket weld, threaded ends and flanged version
 - Size range: DN8 - DN250
 - Pressure range: PN10 - PN100, ANSI 150/300
 - Temperature range: -40°C to +400°C
- For details see page 17 and 18

Series R, Manual operated valves



- Cast and forged body materials
 - Stainless steel, carbon steel
 - Full bore and reduced bore
 - 'Swing-out' center part for easy seat and gasket replacements
 - Butt weld, socket weld, threaded ends and flanged version
 - Size range: DN8 - DN250
 - Pressure range: PN10 - PN100, ANSI 150/300
 - Temperature range: -40°C to +400°C
- For details see page 19 and 20

Series CA, High pressure valves



- Integrated ISO top flange for easy automation
 - Forged body materials.
 - Stainless steel, carbon steel
 - Full bore and reduced bore
 - Butt weld, socket weld, threaded ends and flanged version
 - Size range: DN8 - DN50
 - Pressure range: PN10 - PS220, ANSI 150/300
 - Temperature range: 0°C to +65°C high pressure version
- For details see page 21

Micro-Clean valves



- Forged and cast body
 - Stainless steel version
 - Full and reduced bore
 - Butt weld, OD, extended OD, clamped version
 - Optional electro polished body
 - Internal surface roughness: $0.2 \mu\text{m} < R_a \leq 0.8 \mu\text{m}$
 - Size range: DN8 - DN200
 - Pressure range: PN10 - PN100, ANSI 150/300
 - Temperature range: -40°C to +400°C
- For details see page 30 and 31

Metal seated valves

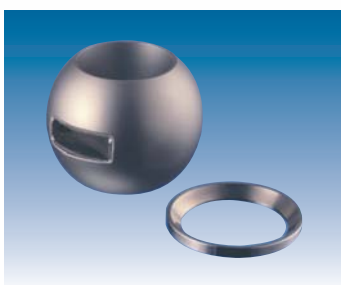

- Full metal seated version for corrosive and abrasive services at elevated temperatures up to 400°C
 - The sealing system can directly be installed in all standard MECAFRANCE 2 and 3 piece ball valves without further modifications.
- For details see page 26 and 27

Note: for detailed body and seat P/T rating information see pages 10 and 11.

3 Piece ball valves

Cryogenic valves



- Cast and forged body materials
 - Stainless steel version only
 - Full and reduced bore
 - Butt weld, socket weld, threaded ends and flanged versions
 - With 150 or 300 mm spindle extensions (other lengths on request)
 - In compliance with EN 1626 (on request)
 - Size range: DN8 - DN150
 - Pressure range: PN10 - PN100, ANSI 150/300 mono-directional
 - Temperature range: -196°C to +80°C
- For details see page 28 and 29

3 Way valves



- Cast and forged body materials
 - Stainless and carbon steel versions
 - Full and reduced bore
 - Flanged, socket, threaded or butt weld center and side connections
 - L-bore, T-bore, horizontal and vertical connections
 - Size range: DN8 - DN150
 - Pressure range: PN10 - PN100 / ANSI 150/300
 - Temperature range: -40°C to +280°C
- For details see page 34 and 35

Tank bottom valves



- Cast and forged body materials
 - Stainless steel version only
 - Full bore
 - 'Swing-out' center part for easy seat and gasket replacements
 - Inlet flange: For direct welding into container bottom
 - Outlet connection: Butt weld, socket weld, threaded ends and flanged version
 - Optional polishes internal/external surfaces
 - Size range: DN15 - DN150
 - Pressure range: PN10 - PN100
 - Temperature range: -40°C to +280°C
- For details see page 36

Valves with heating jacket



- Cast and forged body materials
 - Stainless steel version only
 - Reduced and full bore versions
 - Butt weld, socket weld and threaded version (c/w 1 piece jacket), double versions (c/w 1 piece or 3 piece jacket)
 - 1 Piece jacket: body piece only
 - 3 Piece jacket: body piece including end connections
 - Suitable for tracing with steam, thermal oil, hot water
 - Size range: DN8 - DN200
 - Pressure range valve: PN10 - PN100, ANSI 150/300
 - Pressure range jacket: PN10 standard (ANSI 150 optional)
 - Temperature range: -40°C to +400°C
- For details see page 24 and 25

Micro-Clean, IPC and True-Tube™ valves



- Forged and cast body materials
 - Carbon steel and stainless steel versions
 - Full and reduced bore
 - Integrated ISO top flange for easy automation
 - Hygienic and septic valve designs
 - Size range: DN08 - DN150
 - Pressure range: PN10 - PN100, mono-directional
 - Temperature range: -20°C to +200°C
- For details see page 30, 31, 32 and 33

Note: for detailed body and seat P/T rating information see pages 10 and 11.

2 Piece ball valves

Series EA, flanged cast valves

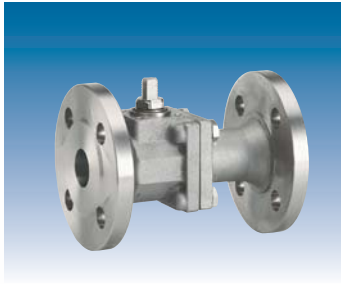

- Cast body materials
 - Carbon steel and stainless steel versions
 - Full bore
 - Integrated ISO top flange for easy automation
 - Size range: DN15 - DN150
 - Pressure range: PN10 - PN40, ANSI 150/300
 - Temperature range: -40°C to +400°C
- For details see page 22

Series ES and EM, flanged valves (forged and cast)



- Forged (series ES) and cast (series EM) body materials
 - Carbon steel and stainless steel versions
 - Full bore
 - Integrated ISO top flange for easy automation
 - Fire tested to BS 6755 part 2, API 607, 3rd edition (series ES)
 - Size range: DN15 - DN150
 - Pressure range: PN10 - PN40, ANSI 150/300 (series ES)
 - Temperature range: -40°C to +400°C or -196°C to +80°C cryogenic application
 - Series ES also available in butt weld, socket weld and threaded versions
- For details see page 23

Note: for detailed body and seat P/T rating information see pages 10 and 11.

Special application valves and actuation

Valves with secondary containment unit



- Forged and cast body materials
 - Carbon steel and stainless steel versions
 - Full and reduced bore
 - To be mounted on series RA, CA, ES, EM and EA
 - Size range: DN8 - DN150
- For details see page 37

Series SG, sight glass



- Stainless steel connections
 - Full bore
 - Butt weld, socket weld, threaded ends and flanged version
 - PTFE or polyethylene gaskets
 - Borosilicate glass
 - Size range: DN15 - DN150
 - Pressure range: PN10 - PN16
 - Temperature range: -20°C to + 200°C
- For details see page 40

Manual operators

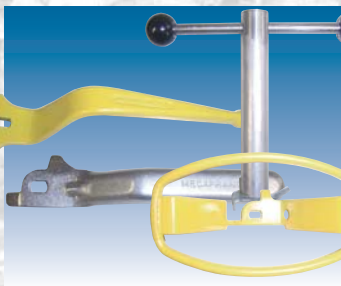

- Stainless steel and carbon steel versions
 - High and low profile handles
 - Lockable handle
 - Round and oval operators
- For details, see page 41

Spring return handle (dead man's lever)



- Action: Spring-to-Open, Spring-to-Close
 - Double inside stop avoids risk of injury
 - Maintenance free due to grease filling
 - Compact, closed housing guaranteeing functionality
 - To be mounted on RA, CA, EA and ES valves
 - ISO interface enabling standard mounting kits
 - Maximum valve size: DN50 reduced bore, and DN40 full bore (PTFE or RTFE seats)
- For details see page 38

Pneumatic actuators



- Single and double acting pneumatic actuators
 - Double rack and pinion design
 - Conforming EN ISO 5211
 - Adjustable, integrated travel stops
 - Anti blow out drive pinion
 - Torque range up to 2.500 Nm
 - 2.75 to 8.3 bar air supply
- For details see page 39

Note: for detailed body and seat P/T rating information see pages 10 and 11.

The MECAFRANCE solution for actuated ball valve packages

Ball valve packages from MECAFRANCE combine high quality valves with reliable actuators and accessories to provide a pre-assembled and tested product ready for on-site installation.

All valves and actuators are manufactured in plants certified to ISO 9001: 2000 and comply with the most stringent requirements of the European

Directives and harmonized standards including Pressure Equipment Directive (97/23/EC PED) and ATEX 94/9/EC for potentially explosive atmospheres. However the real benefits of sourcing valve packages from MECAFRANCE are the savings achieved through dealing with one company able to provide a complete unit specifically designed to operate as an assembly, factory tested and ready for immediate installation and commissioning on site.

MECAFRANCE ball valves include full and reduced bore designs with 2 and 3 piece construction. They are available in diameters from DN8 to DN250 with a full range of connections and ratings and can be supplied in carbon steel, stainless steel with special materials available on request.

General Applications

MECAFRANCE actuated ball valve packages are suitable for most applications from industrial and utilities to heavy duty working conditions including corrosive or hazardous services.

Benefits

- Single source of supply
- Designed to operate as an assembly
- Manufactured in ISO 9001: 2000 certified plants
- All actuated valve packages are individually tested before shipping
- Packages are suitable for incorporation in assemblies requested under the Machinery Directive 98/37/EC. Special ESD valves compliant with this Directive are also available.

Features

- Actuator attachment flanges are EN ISO 5211 compliant
- Brackets and couplings are manufactured to EN standards
- Valves, actuators and accessories comply with the following standards:

Pressure Equipment Directive (97/23/EC PED)

- Valves certified following module H of PED, allowing applications up to and including category III (highest category for industrial valves, table 6 of the PED annex II)
- Actuators falling under article 3, paragraph 3 of the PED are produced in an environment certified to both ISO 9001 and PED module H

ATEX 94/9/EC Potentially Explosive Atmospheres

- Valves and actuators have been assessed to ATEX 94/9 and certified as II 2 GD equipment suitable for installation in all zones 1 and 21 and zones 2 and 22 (according to the ATEX Directive 1999/92/EC annex II)

- Large range of valve diameters, PN or Class designated
- Carbon Steel; Stainless Steel valves as standard, special materials on request
- Valves suitable for On/Off and control service.
- Choice of full or reduced bore valves with 2 or 3 piece body construction
- Control accessories can be mounted on actuator top works and solenoid connections that comply with VDI/VDE 3845.



Quality packages for total peace of mind

Function

Ball sealing

The principle of the ball valves lies in the use of a ported spherical plug which is rotated between two seats normally made of PTFE. The seats have flexible lips designed so that the ball, when rotated, follows the spherical contours of the port way. This floating bearing permits movement in the direction of flow, thereby ensuring optimal sealing of the port way.

Figure 1: in the absence of pressure, a proper seal is assured in that the spring action of the seats presses the sealing lips to the ball; the sealing lips' contact area with the ball is the same on both the upstream and downstream sides.

Figure 2: pressure increases on the upstream side move the ball slightly towards the seat on the downstream side, increasing its pressure against the seat on the downstream side. The seats are designed so that the increase in pressure of the ball on the downstream seat results in all increase in the service contact area, thus preventing any leakage. In addition, such a pressure increase decreases the pressure against the sealing lips on the upstream side. As a result, the operating torque for the valves remains constant throughout the valve's entire pressure range.

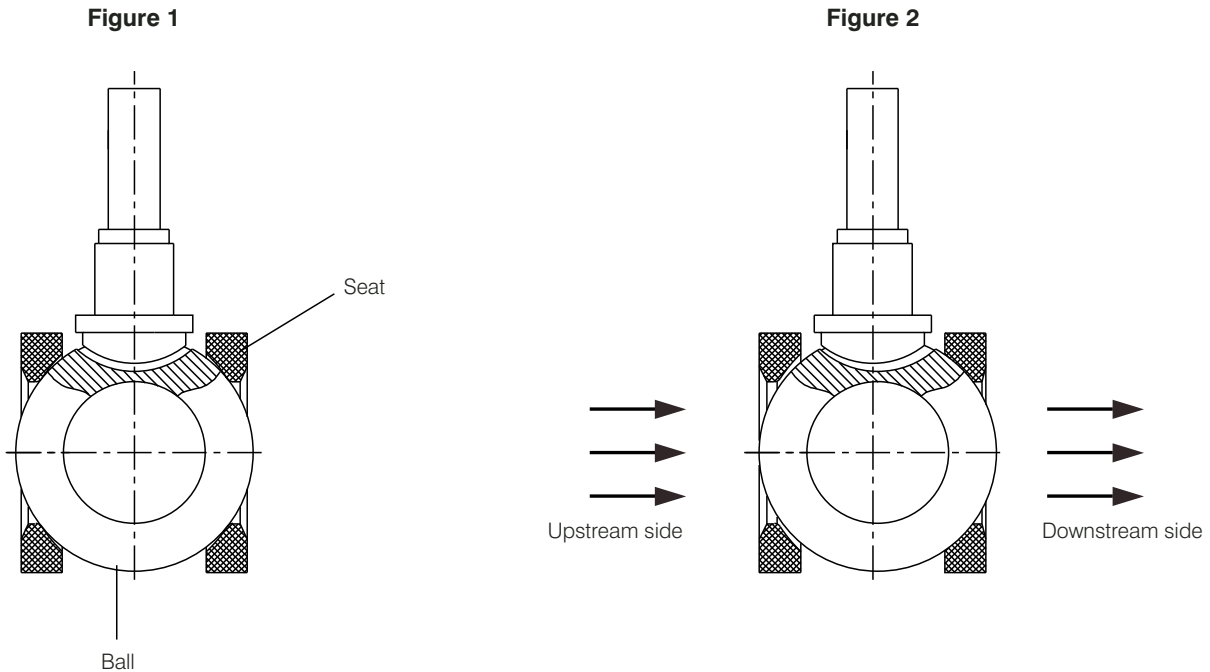

Sealing the shaft

The shaft of the MECAFRANCE ball valve is fitted from inside. A collar, which is larger than the bore in the body, keeps the shaft from being pressed out even under extreme internal pressures. The seat washer inside the shaft provides the primary seal. Any increase in the internal pressure automatically increases the pressure on the shaft collar which, in turn, raises the pressure on the seat seal and the tightness to the outside. For the depressurized state and vacuum mode, the seals are tightened with the secured shaft nut acting on Belleville spring washers and a shaft seal follower; this prevents any leakage. During the vacuum mode, the situation is reversed to the evacuated side. Figure 3 shows the situation when both sides have been evacuated.

Part no.	Description
3	Shaft
6	Shaft seal
7	Shaft packing
8	Shaft packing follower
9	Belleville washer
10	Lock washer
13	Shaft nut

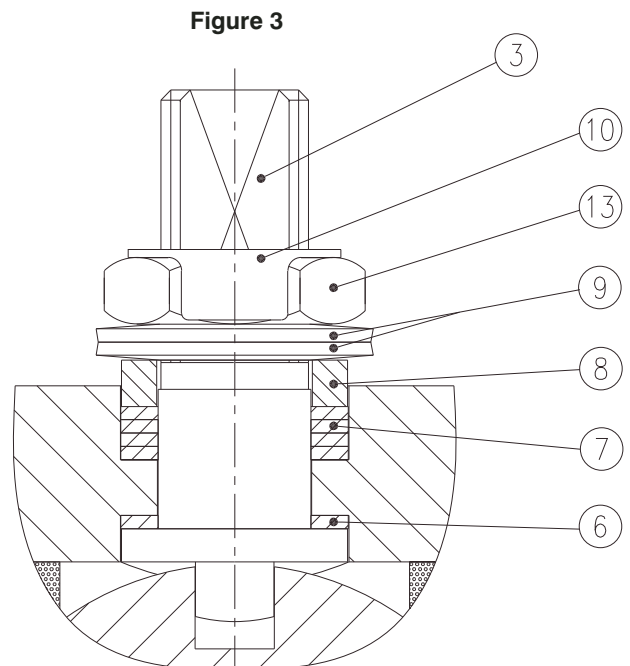

Kv values and pressure losses for reduced bore ball valves

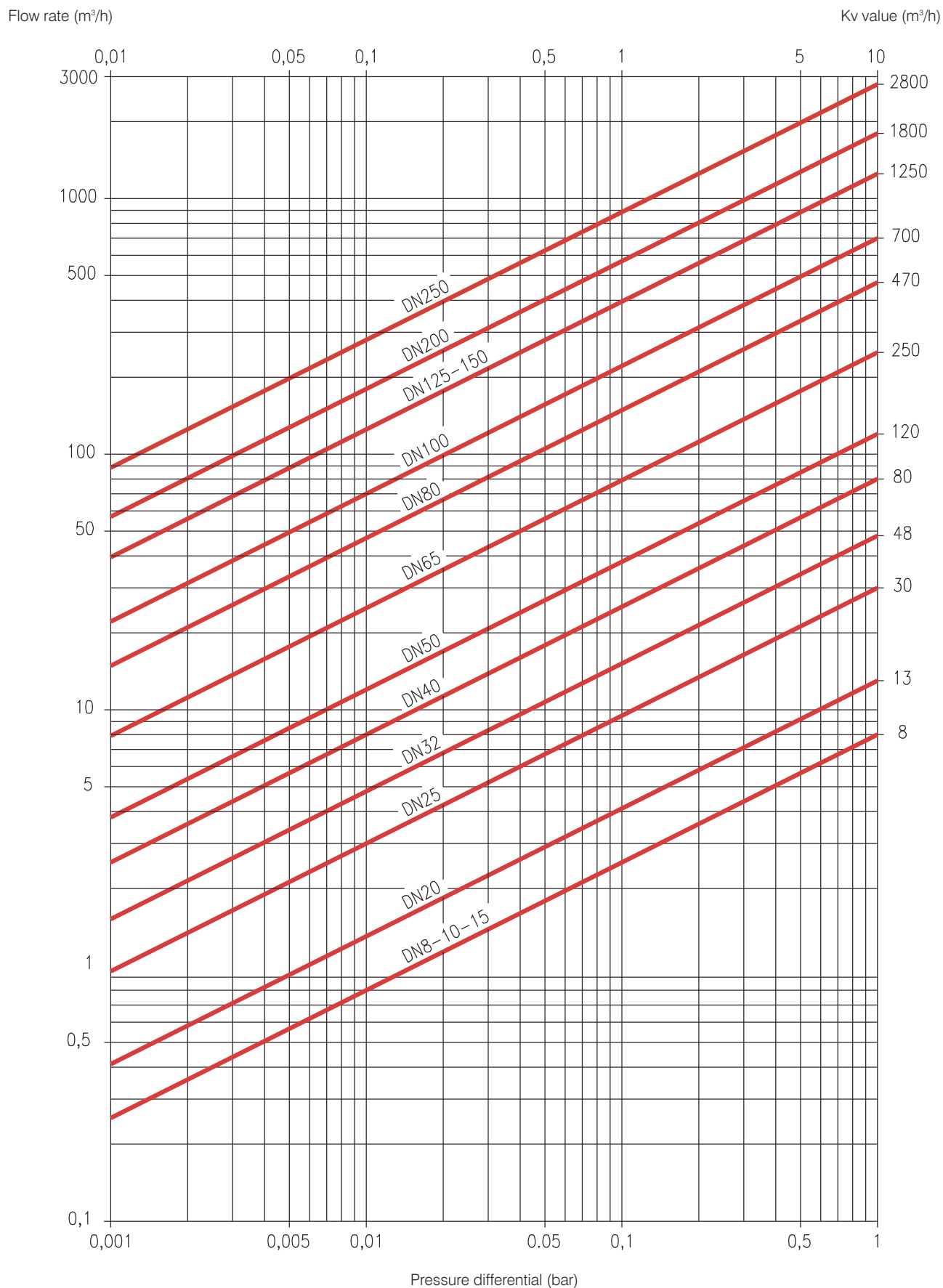

Pressure/Temperature seat ratings

PTFE

For most industrial applications

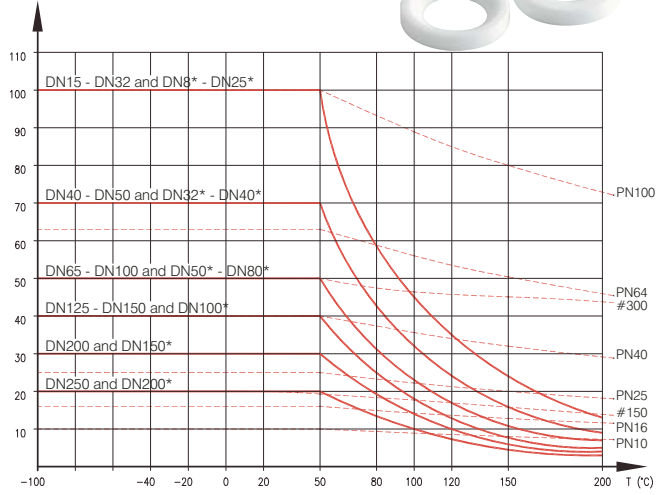

PTFE carbon filled (TF4215)[®]

For high temperature and cryogenic applications

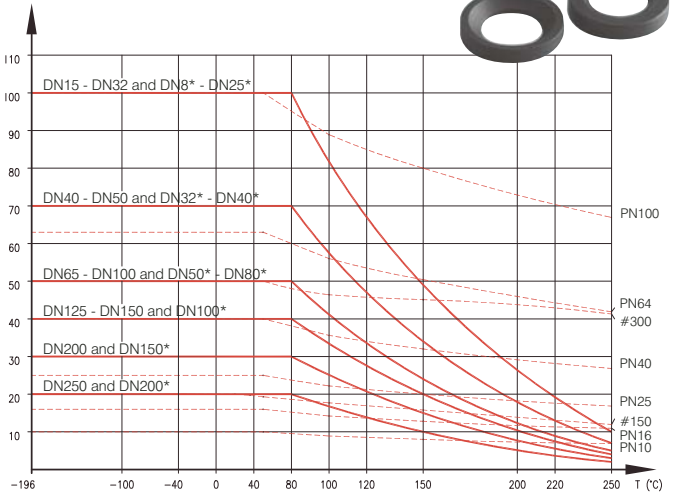

PTFE 15% glass filled

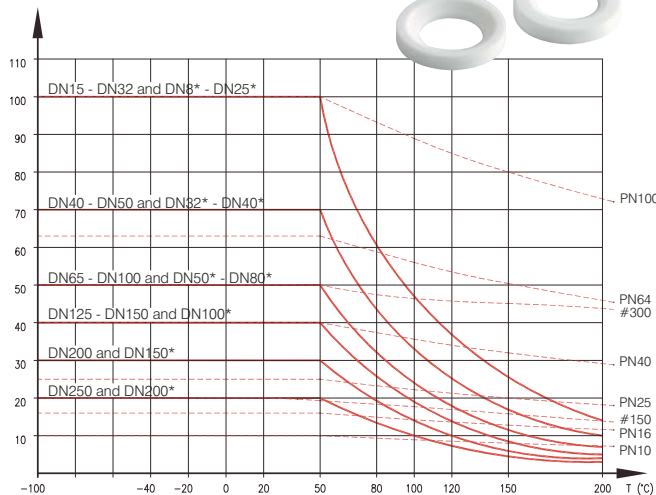

PTFE 50% stainless steel filled

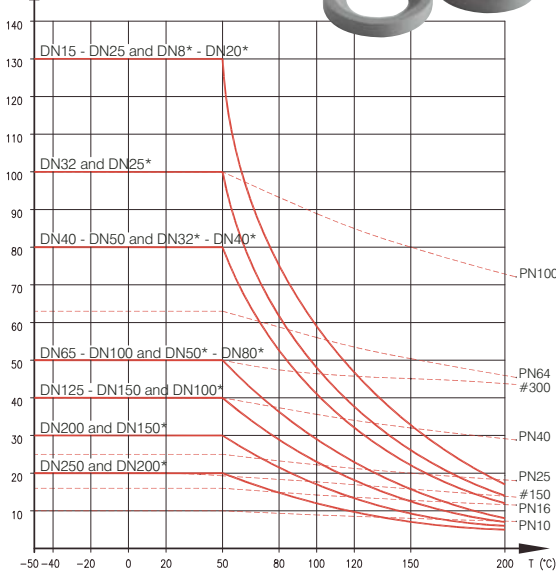

PEEK

For elevated temperature applications

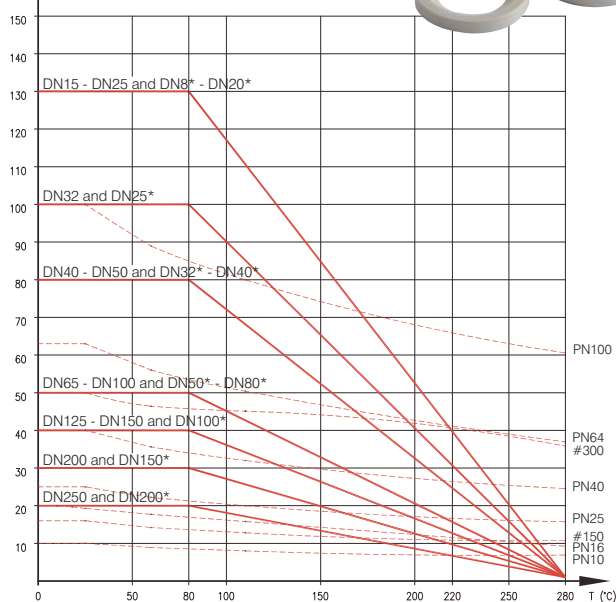

Delrin[®]

For high pressure applications

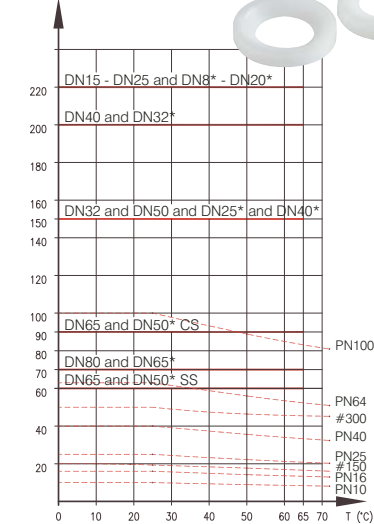

Pressure/Temperature seat ratings

Vespel Seat

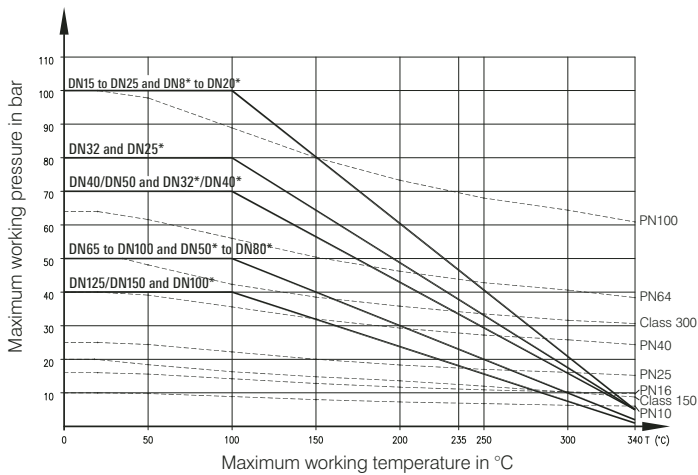

Polyethylene Seat

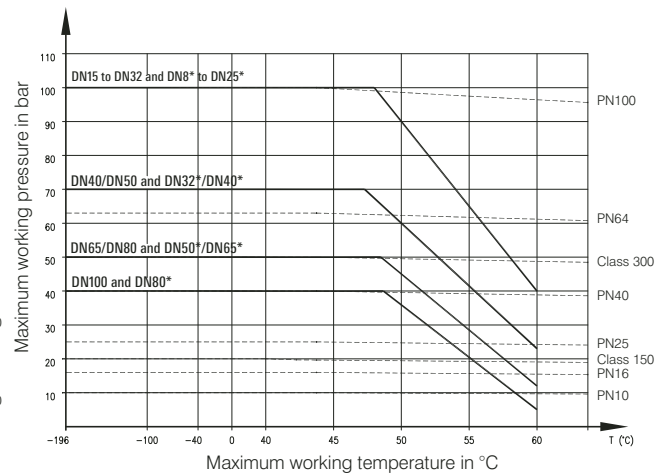

Notes

- * Full bore
- Please always verify maximum body ratings as each above mentioned diagram presents data for the seat material only
- For other material options, please contact your nearest MECAFRANCE representative

Body ratings

Valve type	Flange connection	FiF (1)	Reduced bore		Full bore																
			Full bore	DN8	DN15	DN20	DN25	DN32	DN40	DN50	DN65	DN80	DN100	DN125	DN150	DN200	DN250				
3 Piece valves R, RA, CA, and 3 Way valve	Butt weld	-	Full and reduced bore	100	100	100	100	80	70	70	50	50	50	40	40	30	20				
				100	100	100	80	70	70	50	50	50									
	Socket weld, Threaded	-	-	-	100 *	100	100	63	63	63	40	40	40	40	40	16	16				
					20 *	20	20	20	20	20	20	20	20	20	20	20	20	20	20		
	Flanged PN10 - PN100	Series 1	-	-	50 *	50	50	50	50	50	50	50	50	50							
					50 *	50	50	50	50	50	50	50	50								
Flanged ANSI 300 (PN50)	Series 4	-	-	220	220	220	150	200	150	90 (3)	70										
				220	220	220	150	200	150	90 (3)	70										
2 Piece valves ES	Butt weld	-	Full bore only			100	100	80	70	70	50	50	50		40	30					
						100	100	80													
	Socket weld, Threaded	-	-	-			100	100	63	63	63	40	40	40		40	16				
							20	20	20	20	20	20	20	20	20		20	20			
	Flanged PN10 - PN100	Series 1	-	-			20	20	20	20	20	20	20	20		20	20				
							20	20	20	20	20	20	20	20		20	20				
Flanged ANSI 150 (PN20)	Series 12	-	-			20	20	20	20	20	20	20	20		20	20					
						20	20	20	20	20	20	20	20		20	20					
Flanged ANSI 150 (PN20)	Series 3	-	-			20	20	20	20	20											
						50	50	50	50	50	50	50									
Flanges ANSI 300 (PN50)	Series 4	-	-			40	40	40	40	40	16	16	16		16						
						40	40	40	40	40	40	40		40 (4)	16 (4)						
EM	À bride PN10 - PN40	Series 1	Full bore only			20	20	20	20	20	20	20	20		20	20 (4)					
						50 (4)	50 (4)	50 (4)		50 (4)	50 (4)	50 (4)	50 (4)		50 (4)	50 (4)					
EA	À bride PN10 - PN40	Series 1	Full bore only			40	40	40	40	40	40	40	40		40 (4)	16 (4)					
						20	20	20	20	20	20	20	20		20	20 (4)					
À bride ANSI 150 (PN20)	Series 3	-	-			50 (4)	50 (4)	50 (4)		50 (4)	50 (4)	50 (4)	50 (4)		50 (4)	50 (4)					
						50 (4)	50 (4)	50 (4)		50 (4)	50 (4)	50 (4)	50 (4)		50 (4)	50 (4)					
Brides ANSI 300 (PN50)	Series 4	-	-			50 (4)	50 (4)	50 (4)		50 (4)	50 (4)	50 (4)	50 (4)		50 (4)	50 (4)					
						50 (4)	50 (4)	50 (4)		50 (4)	50 (4)	50 (4)	50 (4)		50 (4)	50 (4)					

Notes

- 1) = according to EN 558
 - 2) = high pressure version with Delrin® seats
 - 3) = for steel bodies, 60 bar for stainless steel bodies
 - 4) = only available in stainless steel bodies
- = Not available
100 = 100 bar body rating
 * = DN15 reduced bore only

Gasket details, operating torques

Body seal

A specially formed PTFE ring, the body gasket, provides the seal to the outside between the body gaskets and the opposing flange. The MECAFRANCE fire-safe design use a tongue and groove connection sealed with temperature-resistant graphite material. High temperatures cause the PTFE seat to vaporize; this, in turn, causes the floating ball to be pressed against the sealing lip during pressure equalization. This results in a metallic linear seal of very high specific are pressure and great reliability. The stem, which has been fitted from inside, is prevented from being pushed out by means of its collar. Even if the PTFE steam seals are completely destroyed, the collar is still pressed against the turned face in the duct, and the tightness increases as the pressure rises.

Both the ball and the stem are sealed off by a metal-to-metal seal if the valve is closed in case of a fire.

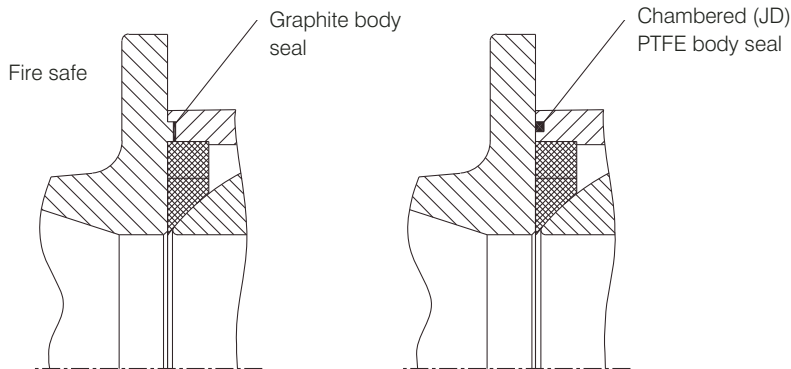

MECAFRANCE valve break away torques (in Nm)

DN		PTFE seats Δp (bar)							
Reduced bore	Full bore	0	6	10	16	25	40	64	100
15	8/10	5	5	5	5	5	9	16	26
20	15	6	6	6	6	6	10	17	27
25	20	11	11	11	11	11	13	19	30
32	25	18	18	18	18	18	22	27	36
40	32	24	24	24	24	24	30	40	55
50	40	30	30	30	30	30	35	35	60
65	50	60	60	60	65	78	102	140	-
80	65	95	95	95	105	120	155	215	-
100	80	155	155	155	165	180	215	275	-
125/150	100	215	215	215	230	250	300	-	-
200	150	325	360	385	400	420	505	-	-
250	200	420	480	720	765	840	-	-	-

DN		PTFE/GFK, HT, HP (DELRIN), CI, PEEK seats Δp (bar)							
Reduced bore	Full bore	0	6	10	16	25	40	64	100
15	8/10	6	6	6	6	6	11	19	31
20	15	7	7	7	7	7	13	20	32
25	20	13	13	13	13	13	17	24	36
32	25	22	22	22	22	22	26	34	43
40	32	29	29	29	29	29	36	48	65
50	40	36	36	36	36	36	43	55	72
65	50	72	72	72	81	94	122	170	-
80	65	115	115	115	125	145	190	260	-
100	80	180	180	180	190	210	250	315	-
125/150	100	250	250	250	265	290	350	-	-
200	150	370	415	450	460	485	580	-	-
250	200	480	550	830	885	970	-	-	-

DN		Cryogenic PTFE seats Δp (bar)							
Reduced bore	Full bore	0	6	10	16	25	40	64	100
15	8/10	7	7	7	7	7	14	24	40
20	15	10	10	10	10	10	16	26	41
25	20	17	17	17	17	17	20	29	46
32	25	28	28	28	28	28	32	42	54
40	32	36	36	36	36	36	46	60	82
50	40	46	46	46	46	46	54	68	88
65	50	90	90	90	100	118	154	210	-
80	65	144	144	144	155	180	235	320	-
100	80	235	235	235	250	270	325	410	-
125/150	100	325	325	325	345	380	450	-	-
200	150	485	540	575	595	630	755	-	-
250	200	630	720	1080	1150	1260	-	-	-

Notes

- Operating torque in Nm, in clean water at room temperature
- For the actuator torque, multiply above value by 1.5
- For non lubricating media, please add 20% to the torques specified

Body bolting pattern, flange bolting torques, packing torques

Body bolting pattern in case blind flanges are required

Version D

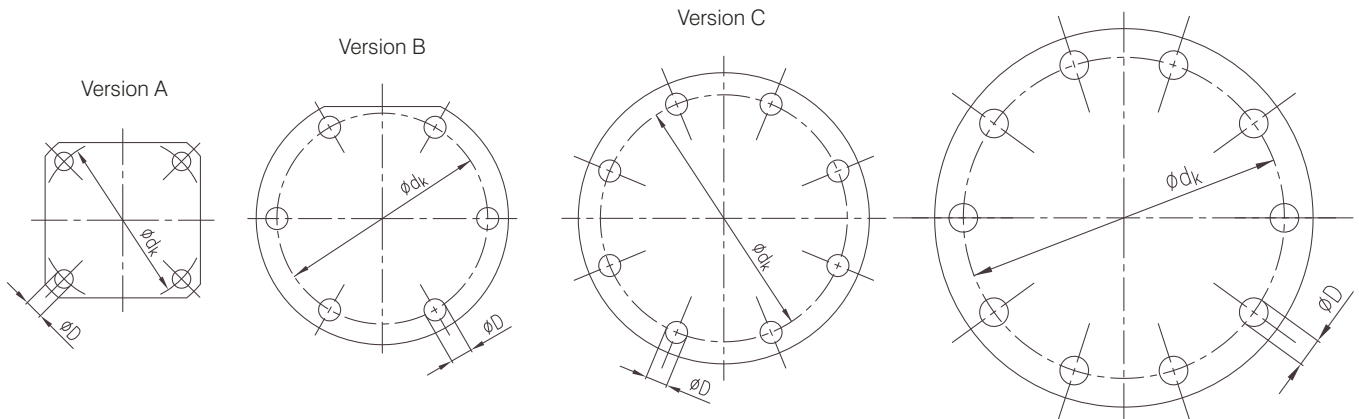

Dimensions for master gauge for holes

DN		Ø D	Ø dk	Screws	Series	Version
Reduced bore	Full bore					
15	8/10	6,5	45	4 x M6	R / RA / CA	A
20	15	8,5	53,1	4 x M8	R / RA / CA	A
25	20	8,5	62,8	4 x M8	R / RA / CA	A
32	25	8,5	71,8	4 x M8	R / RA / CA	A
40	32	10,5	80,9	4 x M10	R / RA / CA	A
50	40	10,5	94,2	4 x M10	R / RA / CA	A
65	50	13	114 [1] 119,5 [2]	6 x M12	R / RA	B
80	65	13	140	6 x M12	R / RA	C
100	80	15	175	8 x M14	R / RA	C
125/150	100	15	206	8 x M14	R / RA	C
200	150	19	314	8 x M18	R / RA	C
250	200	22	388	10 x M20	R / RA	D

Torque Series R/RA/CA

Body screws and nuts

Ball valves reduced bore (standard) DN	Ball valves full bore (integral) DN	Thread	M _d (Nm)
-	8	M6	11-13
15	10	M6	11-13
20	15	M8	14-18
25	20	M8	14-18
32	25	M8	14-18
40	32	M10	27-33
50	40	M10	27-33
65	50	M12	72-88
80	65	M12	72-88
100	80	M14	108-132
125/150	100	M14	108-132
200	150	M18	180-220
250	200	M20	243-297

Torque Series ES/EA/EM

Body screws and nuts

Ball valves full bore (integral) DN	Thread	M _d (Nm)
15	M8	14-18
20	M10	14-18
25	M10	27-33
32	M10	27-33
40	M12	27-33
50	M12	72-88
65	M12	72-88
80	M16	108-132
100	M16	108-132
150	M16	180-220

Notes

- Direct from the factory, body screws are tightened with the indicated torques. These torques are for undamaged threads, direct from the factory.
- After tightening the stem nut with the specified torque, the correct position of the lock washer according to our assembly and maintenance instructions has been ensured.
- Indicated torques are applied during the assembly process.
- [1] = Stainless Steel, [2] = Carbon Steel

Stem nuts: Series R/RA/CA/ES and EA/EM

(PTFE/GFK Antistatic Packing Assembly)

Ball valves Reduced bore (standard) DN	Ball valves full bore (integral) DN	M _d (Nm)
15/20	8/10/15	8
25/32	20/25	14
40/50/65	32/40/50	20
65 (reinforced version)	50 (reinforced version)	39
80/100/125/150	65/80/100	85
200	150	200
250	200	270

Exploded view 3 piece ball valves Series RA

**Ball valve of series RA with reduced bore
DN15 to DN50; CBS**

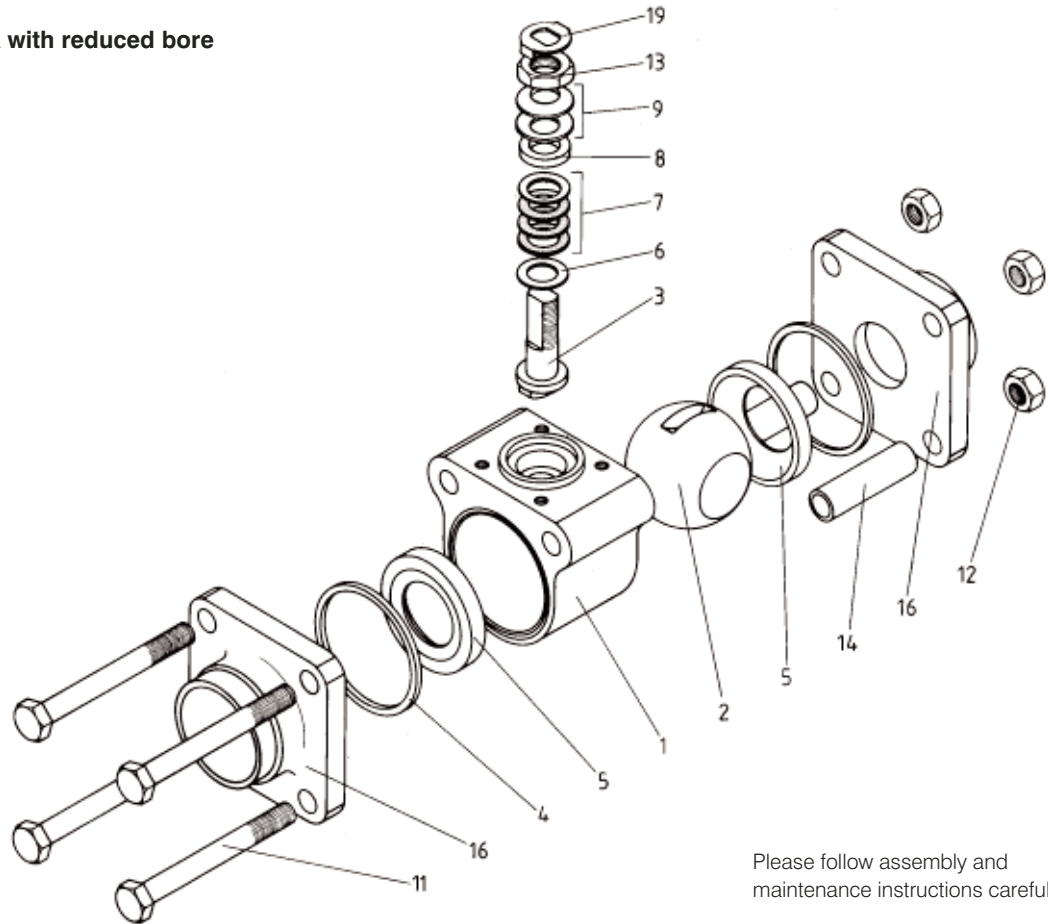

Please follow assembly and maintenance instructions carefully.

**Ball valve series RA with reduced bore
DN15 to DN50; CBF**

Spare parts numbers

- 1 Body
- 2 Ball
- 3 Shaft
- 4 Body gasket
- 5 Seat
- 6 Shaft seal
- 7 Shaft packing
- 8 Shaft packing follower
- 9 Belleville washer
- 10 Lock washer
- 11 Tie rod/Body bolt
- 12 Nut
- 13 Shaft nut
- 14 Sleeve
- 16 End piece
- 17 Flange end
- 18 Handle
- 19 Lock washer
- 27 Travel stop

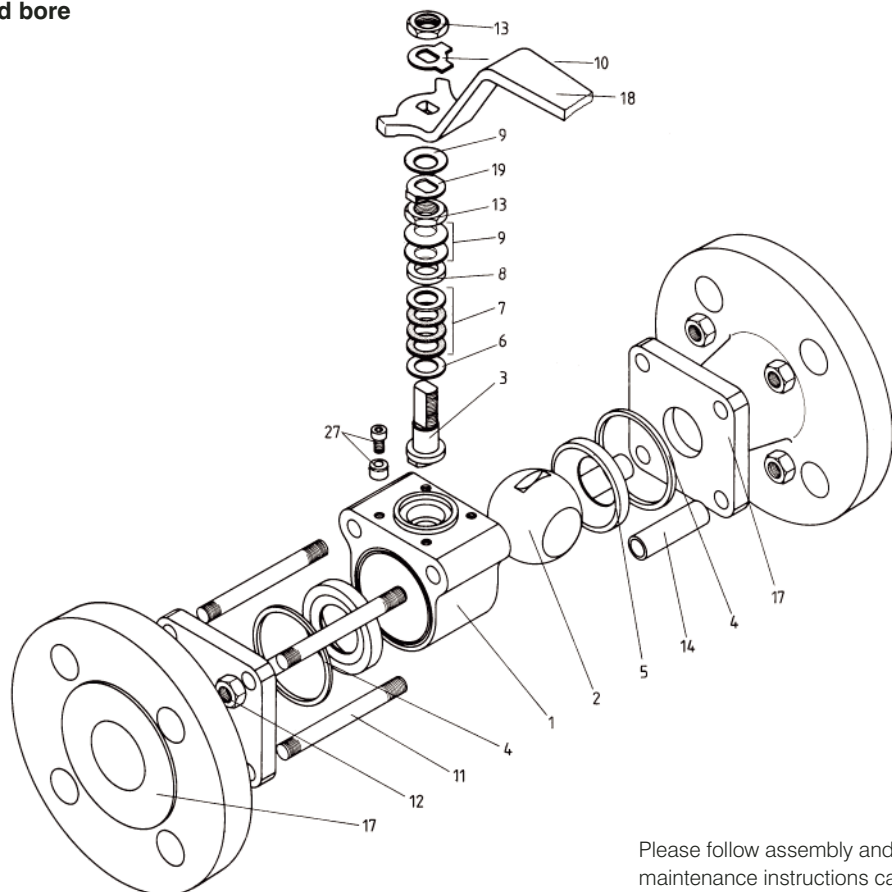

Please follow assembly and maintenance instructions carefully.

Exploded view 3 piece ball valves Series R

**Ball valve of series R with reduced bore
(standard version)
DN15 to DN65
Example shown: Series R DN65**

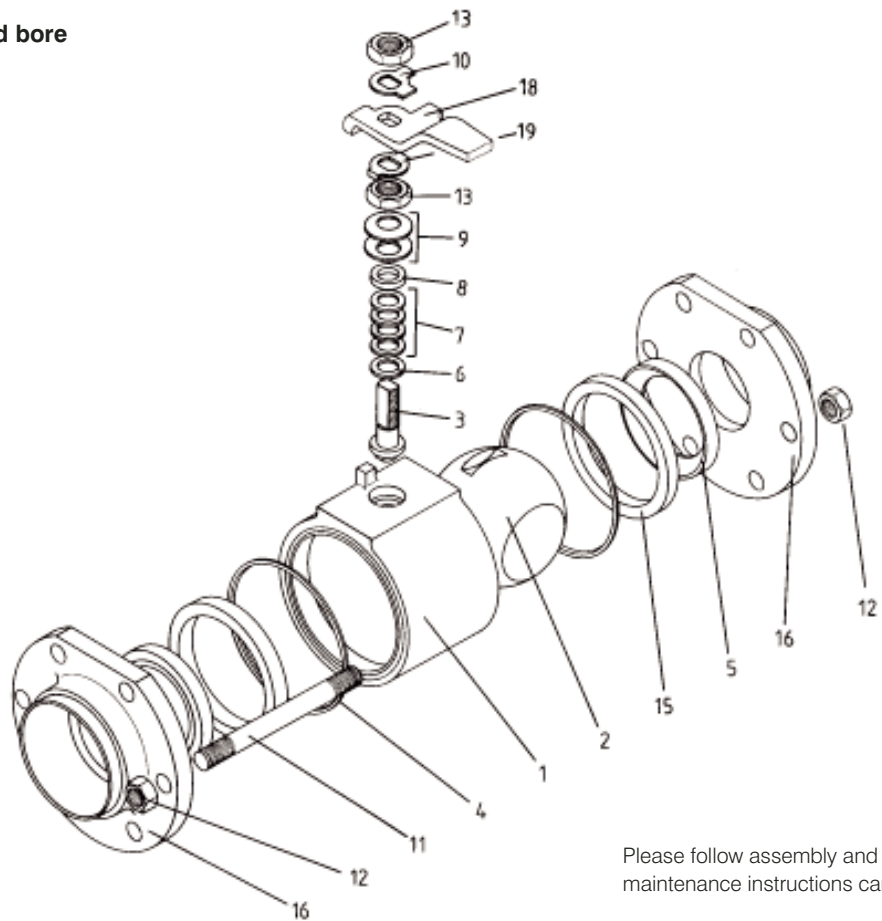

Please follow assembly and maintenance instructions carefully.

**Ball valve series R with reduced bore
DN80 - DN250**

Spare parts numbers

- 1 Body
- 2 Ball
- 3 Shaft
- 4 Body gasket
- 5 Seat
- 6 Shaft seal
- 7 Shaft packing
- 8 Shaft packing follower
- 9 Belleville washer
- 10 Lock washer
- 11 Tie rod
- 12 Nut
- 13 Shaft nut
- 15 Centering ring
- 16 Butt weld end
- 18 Handle
- 19 Lock washer
- 20 Stop
- 23 Washer
- 24 Fixing screw

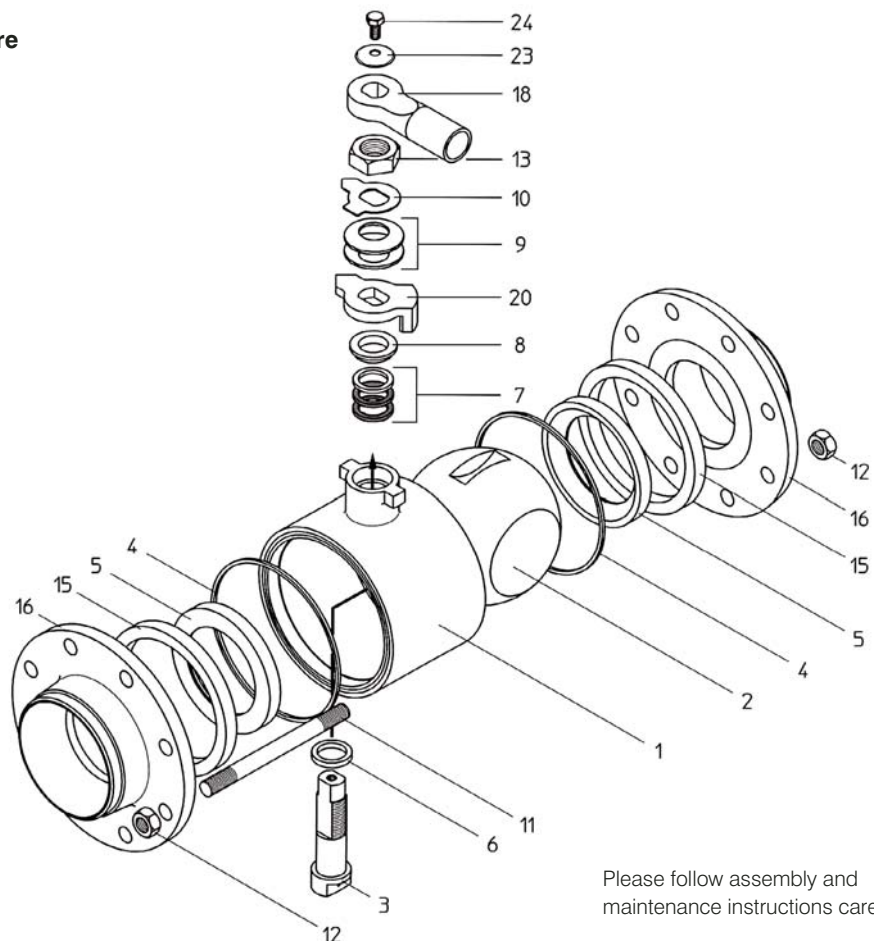

Please follow assembly and maintenance instructions carefully.

Material specification

Designation	Valves of carbon steel		Valves of stainless steel	
	DIN	AISI/ASTM	DIN	AISI/ASTM
1 Body	1.0352/1.0460/1.0619/ P250GH/P240GH	A105/A216 WCB	1.4404/1.4408	316L/CF8M
2 Ball	1.4404/1.4408	1.4404/1.4408	1.4404/1.4408	316L/CF8M
3 Stem	1.4404/1.4462	316L	1.4404/1.4462	316L
4 Body gasket	PTFE/PTFE stainless/ PTFE-Graphite (TF4215)*/ graphite/ Vespel/Peek/ Polyéthylène/PCTFE/ Viton/TFM1600	PTFE/PTFE stainless/ PTFE-Graphite (TF4215)*/ graphite/ Vespel/Peek/ Polyéthylène/PCTFE/ Viton/TFM1600	PTFE/PTFE stainless/ PTFE-Graphite (TF4215)*/ graphite/ Vespel/Peek/ Polyéthylène/PCTFE/ Viton/TFM1600	PTFE/PTFE stainless/ PTFE-Graphite (TF4215)*/ graphite/ Vespel/Peek/ Polyéthylène/PCTFE/ Viton/TFM1600
5 Seat	PTFE/ PTFE-Graphite (TF4215)*/ PTFE glass filled/ PTFE stainless steel filled/ PEEK/ Delrin*/ Vespel/ Polyéthylène/ TFM1600/ Métal	PTFE/ PTFE-Graphite (TF4215)*/ PTFE glass filled/ PTFE stainless steel filled/ PEEK/ Delrin*/ Vespel/ Polyéthylène/ TFM1600/ Métal	PTFE/ PTFE-Graphite (TF4215)*/ PTFE glass filled/ PTFE stainless steel filled/ PEEK/ Delrin*/ Vespel/ Polyéthylène/ TFM1600/ Métal	PTFE/ PTFE-Graphite (TF4215)*/ PTFE glass filled/ PTFE stainless steel filled/ PEEK/ Delrin*/ Vespel/ Polyéthylène/ TFM1600/ Métal
6 Stem seal	PTFE-glass-reinforced/ PTFE-graphite/PE Nitalon (HP)/ TFM1600/ PTFE trame inox/ Graphite/ Vespel/Peek/ Viton/PCTFE	PTFE-glass-reinforced/ PTFE-graphite/PE Nitalon (HP)/ TFM1600/ PTFE trame inox/ Graphite/ Vespel/Peek/ Viton/PCTFE	PTFE-glass-reinforced/ PTFE-graphite/PE Nitalon (HP)/ TFM1600/ PTFE trame inox/ Graphite/ Vespel/Peek/ Viton/PCTFE	PTFE-glass-reinforced/ PTFE-graphite/PE Nitalon (HP)/ TFM1600/ PTFE trame inox/ Graphite/ Vespel/Peek/ Viton/PCTFE
7 Stem packing (antistatic)	PTFE-GFK antistatic/ PTFE graphite/ PTFE FPM*/ TFM1600/ Polyethylene PTFE trame inox/ Graphite/ Vespel/Peek/ Viton/PCTFE	PTFE-GFK antistatic/ PTFE graphite/ PTFE FPM*/ TFM1600/ Polyethylene PTFE trame inox/ Graphite/ Vespel/Peek/ Viton/PCTFE	PTFE-GFK antistatic/ PTFE graphite/ PTFE FPM*/ TFM1600/ Polyethylene PTFE trame inox/ Graphite/ Vespel/Peek/ Viton/PCTFE	PTFE-GFK antistatic/ PTFE graphite/ PTFE FPM*/ TFM1600/ Polyethylene PTFE trame inox/ Graphite/ Vespel/Peek/ Viton/PCTFE
8 Stem packing follower	1.4301	304	1.4301	304
9 Belleville washer	1.431	302	1.431	302
10 Lock washer	1.4306	304L	1.4306	304L
11 Body screw	8.8	A 193 B 7	A 2-70	A 193 B 8
12 Nut	8	A 194 2 H	A 2-70	A 194 8
13 Stem nut	1.0715	115	1.4301	304
14 Sleeve	PTFE	PTFE	PTFE	PTFE
15 Centering ring	PTFE-glass-reinforced/ stainless steel Polyethylene	PTFE-glass-reinforced/ stainless steel Polyethylene	PTFE-glass-reinforced/ stainless steel Polyethylene	PTFE-glass-reinforced/ stainless steel Polyethylene
16 Welding end	1.0460/	A105	1.4404	316L
17 Flange end	1.0619/1.0460	A105/A216 WCB	1.4404/1.4408	316L/CF8M
18 Handle	C-15/ stainless steel	A105/ stainless steel	C-15/ stainless steel	A105/ stainless steel
19 Lock washer	1.4306	304L	1.4306	304L
20 Stop	Cast iron	Cast iron	1.4308	CF-8
22 Threaded end	1.0460	A105	1.4404	316L
23 Washer	1.4301	304	1.4301	304
24 Fixing screw	1.4301	304	1.4301	304
Sight glass	Borosilicate glass	Borosilicate glass	Borosilicate glass	Borosilicate glass
Protective screen	1.4301	304	1.4301	304
Chain	Steel/stainless steel	Steel/stainless steel	Steel/stainless steel	Steel/stainless steel
Sealing cap	PE/1.4408	PE/CF8M	PE/1.4408	PE/CF8M
Stem extension	1.4306	A312	1.4306	A312

Series RA

3 Piece ball valves with ISO top flange DN8 - DN50
Butt weld, threaded, socket weld and flanged version

RA 66 CBS DN25

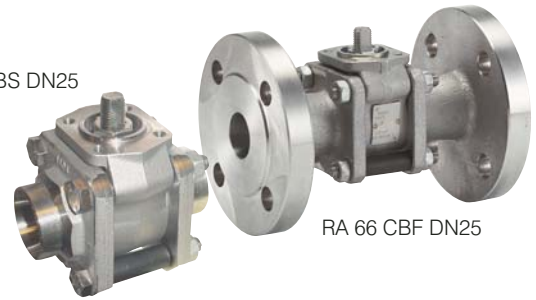

RA 66 CBF DN25

DN8 - DN25

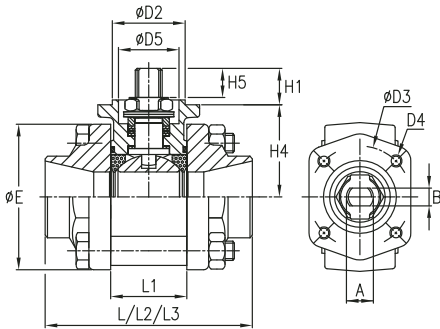

DN32 - DN50

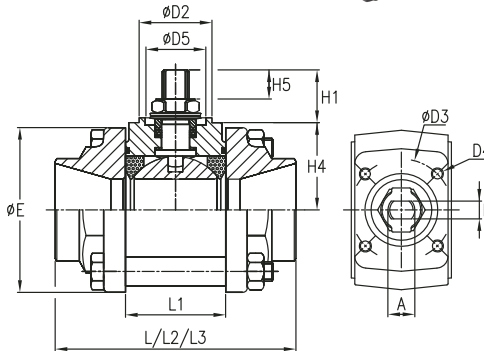

Available end connection options:

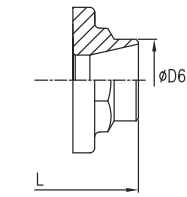

Butt weld: CBS

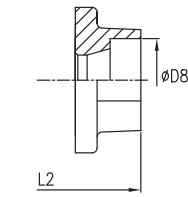

Socket weld: CBSW

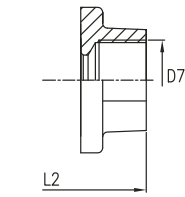

Threaded: CBG

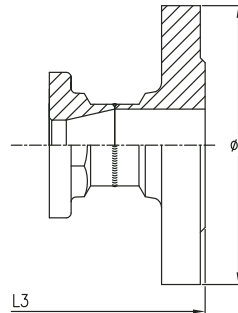

Flanged: CBF
(Cast versions available on request)

Design features

- ISO top flange according DIN/ISO 5211/DIN 3337 available with or without handle
- Easy installation of all types of actuators
- Swing out body for easy maintenance
- Flexible installation features due to modular design
- Reduced and full bore options available
- Stainless and carbon steel trims
- Forged end connections
- Cast and forged body materials
- Wide variety of seat material options available

Detailed technical information

- Threaded ends: (CBG) BSPP, BSPT according DIN 2999, DIN 259 (CBB) NPT according ANSI B 1.20
- Socket weld (CBSW): Female socket weld ANSI B16.11
- Butt weld (CBS): ISO, DIN, ASME, OD, extended OD
- Flanged (CBF): Cast and forged design EN 1092-1, ANSI 150/300. Standard Face-to-Face according EN 558 Series 1
- Design codes: DIN 3840, EN 13445
- DN8 - DN32: Forged and cast bodies. Larger sizes in cast body material
- Special end connections are available on request
- Pressure rating: PN10 - PN100

Dimensions in mm

DN	ISO 5211	L	L1	L2	L3	H1	H4	H5	øE	øD	øD2	øD3	D4	øD5	øD6	D7	øD8	A	B	Ball bore	Weight in Kg			
																					CBS	CBSW	CBF CBG	
																						series 1		
8	F03	65	20.4	65	-	10	30	7	45	-	25	36	M5	22	13.5	1/4"	14.2	9.5	5.4	11.1	0.5	0.5	-	
10	F03	65	20.4	65	130	10	30	7	45	90	25	36	M5	22	17.2	3/8"	17.6	9.5	5.4	11.1	0.5	0.5	2.2	
15	F03	65	20.4	65	130	10	30	7	45	95	25	36	M5	22	21.3	1/2"	21.8	9.5	5.4	11.1	0.5	0.5	2.3	
20	F03	72.5	24.5	72.5	150	10	32	7	52	105	25	36	M5	22	26.9	3/4"	27.4	9.5	5.4	14.2	0.8	0.9	3	
25	F04	85.4	31.4	85.4	160	15	38	12	60	115	30	42	M5	25	33.7	1"	34.2	11.1	7.5	20.6	1.1	1.3	3.8	
32	F04	99.3	41.3	99.3	180	22	36	12	68	140	30	42	M5	25	42.4	1 1/4"	43	11.1	7.5	25.4	1.7	1.9	6	
40	F05	110.4	48.4	110.4	200	29	42	16	76	150	35	50	M6	30	48.3	1 1/2"	49	14.3	8.9	31.7	2.7	2.7	7.3	
50	F05	126.3	56.3	126.3	230	30	46	16	88	165	35	50	M6	30	60.3	2"	61.1	14.3	8.9	38	3.8	4.1	10	

Notes

- All dimensions are related to reduced bore valves. For full bore valves please apply the dimensions of the next diameter (except L3, øD, øD6, D7 and øD8 which is identical in both instances)

Series RA

3 Piece ball valves with ISO top flange DN65 - DN250
Butt weld, threaded, socket weld and flanged version



RA 66 CBF DN100

DN80 - DN250

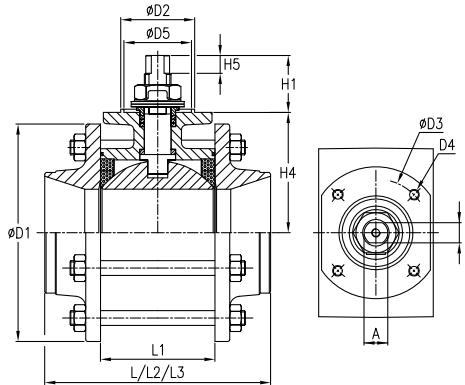
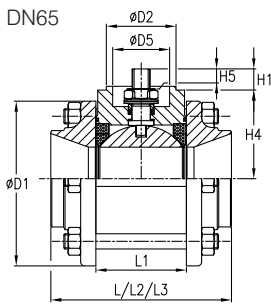

Available end connection options:

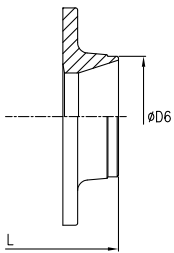

Butt weld: CBS

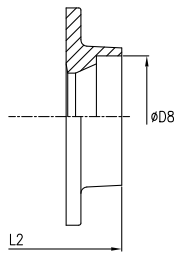

Socket weld: CBSW

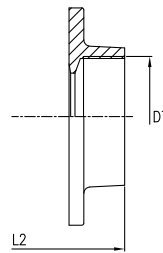

Threaded: CBG

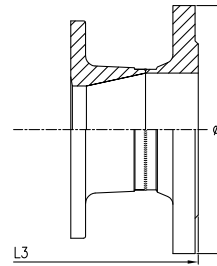

Flanged: CBF
(Cast versions available on request)

Approvals and certificates

- TA-Luft according VDI 2440
- CE marking: Module H, category III
- Fire tested according BS 6755
- Lloyds register type approval
- DIN-GOST on request
- TÜ.AGG and TÜ.VAR type approval

CE - PED module H, up to category III
- TPED module H, up to category III

Dimensions in mm

DN	ISO	L	L1	L2	L3	H1	H4	H5	ØD	ØD1	ØD2	ØD3	D4	ØD5	ØD6	D7	ØD8	A	B	Ball bore	Weight in Kg		
																					CBS	CBSW	CBF CBG
65	F07	142.6	71.4	160	290	16	70	16	185	143	55	70	M8	45	76.1	2 1/2"	77	14.3	8.9	50	6.6	6.8	16
80	F07	169.5	88.9	180	310	54	99	17	200	165	55	70	M8	45	88.9	3"	90	22.5	19	62	12.6	13	26
100	F10	214	108.5	214	350	54	114	17	220	206	70	102	M10	64	114.3	4"	115.5	22.5	19	82.4	23	23	34
125	F10	277	134.6	-	400	54	128	17	250	234	70	102	M10	64	139.7	-	-	22.5	19	100	37	-	47
150	F10	307	134.6	-	480	54	128	17	285	234	70	102	M10	64	168.3	-	-	22.5	19	100	40	-	56
200	F12	409	189.1	-	600	72	186	28	340	345	85	125	M12	65	219.1	-	-	35	28.5	150	84	-	133
250	F14	460	248	-	730	77	228	28	405	428	100	140	M16	-	273	-	-	38	30	200	150	-	200

Notes

- All dimensions are related to reduced bore valves. For full bore valves please apply the dimensions of the next diameter (except L3, ØD, ØD6, D7 and ØD8 which is identical in both instances)

Series R

3 Piece ball valves with integrated handle DN8 - DN50
Butt weld, threaded, socket weld and flanged version

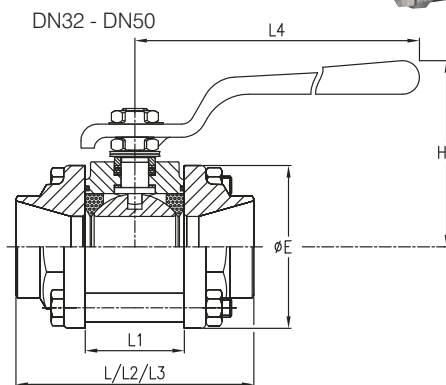
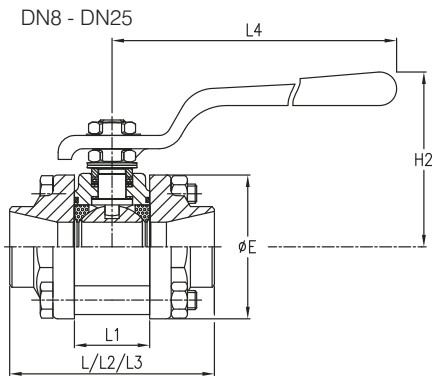

Available end connection options:

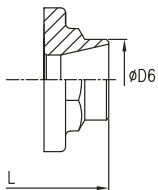

Butt weld: CBS

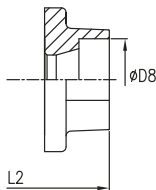

Socket weld: CBSW

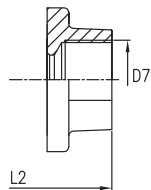

Threaded: CBG

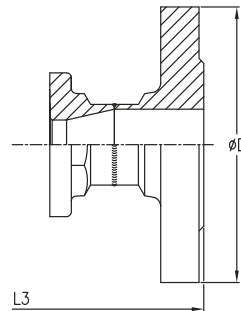

Flanged: CBF
(Cast versions available on request)

Design features

- Swing out body for easy maintenance
- Flexible installation features due to modular design
- Rugged design
- Reduced and full bore options available
- Stainless and carbon steel trim
- Forged end connections
- Cast and forged body materials
- Wide variety of seat material options available

Detailed technical information

- Threaded ends: (CBG), CBG according ISO 288-1, CBG conical according ISO 7 and NPT according ANSI B 1.20
- Socked weld (CBSW): Female socket weld ANSI B16.11
- Butt weld (CBS): ISO, DIN, ASME, OD, extended OD
- Flanged (CBF): Cast and forged design EN 1092-1, EN 1759-1. Standard Face-to-Face according EN 558 Series 1
- Design codes: DIN 3840, EN 13445
- DN8 - DN50: Forged bodies (forged up to DN100 on request). Larger sizes in cast body material.
- Special end connections are available on request
- Pressure rating: PN10 - PN100

Dimensions in mm

DN	L	L1	L2	L3	L4	H2	ØE	ØD	ØD6	D7	ØD8	Ball bore	Weight in Kg			
													CBS	CBSW	CBF	
series 1																
8	65	20.4	65	-	140	53	45	-	13.5	1/4"	14.2	11.1	0.5	0.5	-	
10	65	20.4	65	130	140	53	45	90	17.2	3/8"	17.6	11.1	0.5	0.5	2.2	
15	65	20.4	65	130	140	53	45	95	21.3	1/2"	21.8	11.1	0.5	0.5	2.2	
20	72.5	24.5	72.5	150	140	56	52	105	26.9	3/4"	27.4	14.2	0.8	0.9	3.1	
25	85.4	31.4	85.4	160	180	73	60	115	33.7	1"	34.2	20.6	1.3	1.4	3.9	
32	99.3	41.3	99.3	180	180	78	68	140	42.4	1 1/4"	43	25.4	1.9	1.9	6.1	
40	110.4	48.4	110.4	200	200	90	76	150	48.3	1 1/2"	49	31.7	2.8	2.8	7.4	
50	126.3	56.3	126.3	230	200	95	88	165	60.3	2"	61.1	38	3.9	4.1	10	

Notes

- All dimensions are related to reduced bore valves For full bore valves please apply the dimensions of the next diameter (except L3, ØD, ØD6, D7 and ØD8 which is identical in both instances)

Series R

3 Piece ball valves with integrated handle DN65 - DN250
Butt weld, threaded, socket weld and flanged version



R 66 CBS DN100

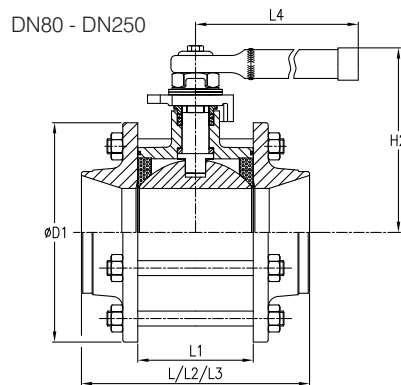
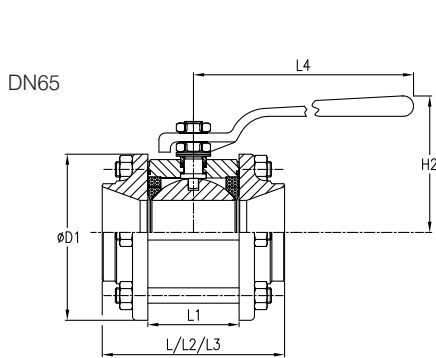

Available end connection options:

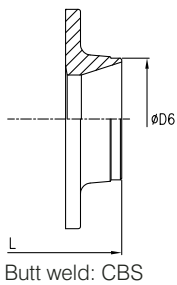

Butt weld: CBS

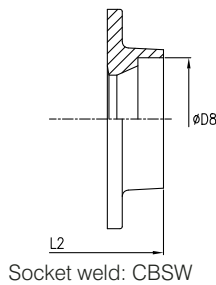

Socket weld: CBSW

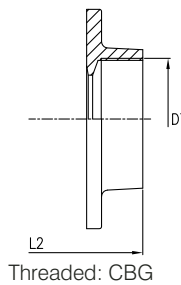

Threaded: CBG

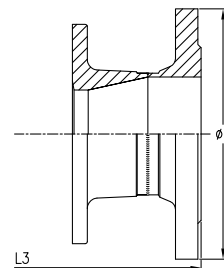

Flanged: CBF
(Cast versions available on request)

Approvals and certificates

- TA-Luft according VDI 2440
- CE marking: Module H, category III
- Fire tested according BS 6755
- Lloyds register type approval
- DIN.Tü.AGG, TÜV.AR type approval

CE - PED module H, up to category III
- TPED module H, up to category II

Dimensions in mm

DN	L	L1	L2	L3	L4	H2	øD	øD1	øD6	D7	øD8	Ball bore	Weight in Kg		
													CBS	CBSW CBG	CBF
65	142.6	71.4	160	290	250	106	185	143	76.1	2 1/2"	77	50	6.7	6.8	16
80	169.5	88.9	180	310	480	156.5	200	165	88.9	3"	90	62	13	13	26
100	214	108.5	214	350	480	171.5	220	206	114.3	4"	115.5	82.4	23	23	34
125	277	134.6	-	400	480	185.5	250	234	139.7	-	-	100	37	-	47
150	307	134.6	-	480	480	185.5	285	234	168.3	-	-	100	40	-	56
200	409	189.1	-	600	720	262	340	345	219.1	-	-	150	85	-	134
250	460	248	-	730	800	310	405	428	273	-	-	200	150	-	200

Notes

- All dimensions are related to reduced bore valves. For full bore valves please apply the dimensions of the next diameter (except L3, øD, øD6, D7 and øD8 which is identical in both instances)

Series CA

3 Piece high pressure ball valves with ISO top flange DN8 - DN50
Butt weld, threaded, socket weld and flanged version

CA 66 CBS DN25

CA 66 CBF DN32



DN8 - DN25

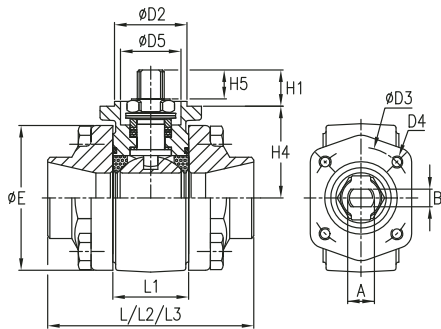

DN32 - DN50

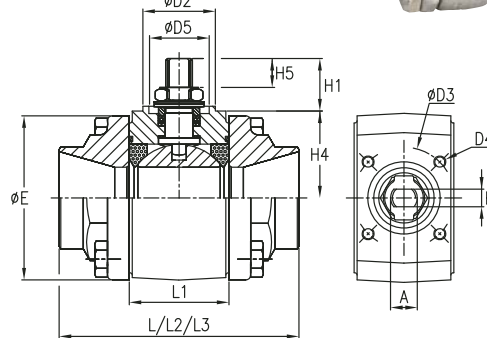

Available end connection options:

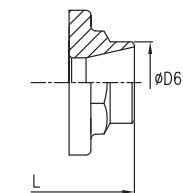

Butt weld: CBS

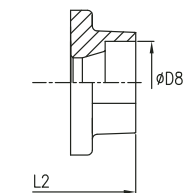

Socket weld: CBSW

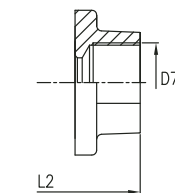

Threaded: CBG

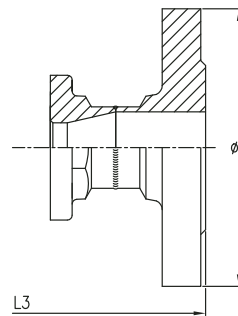

Flanged: CBF
(Cast versions available on request)

Design features

- Pressure rating with welded ends:
 - 220 bar for DN15 - DN25 reduced bore and DN8 - DN20 full bore
 - 150 bar for DN32 - DN50 reduced bore and DN25 - DN40 full bore
- Pressure rating with double flanges:
 - PN 100 for DN15 - DN25 reduced bore and DN8 - DN20 full bore
 - PN 63 for DN32 - DN50 reduced bore and DN25 - DN40 full bore
- Delrin® seats only
- Integrated ISO top flange for easy automation
- Body incorporates threaded end piece connection holes
- Stainless steel or carbon steel trim

Detailed technical information

- Threaded ends: CBG according ISO 288-1, CBG conical according ISO 7 and NPT according ANSI B.120
- Socket weld (CBSW): Female socket weld ANSI B16.11
- Butt weld (CBS): ISO, DIN, ASME, OD, extended OD
- Flanged (CBF): Cast and forged design EN 1092-1, EN 1759-1. Standard Face-to-Face according EN 558 Series 1
- Design code: EN 13445
- DN8 - DN50: Forged bodies
- Special end connections are available on request

CE - PED module H, up to category III
- TPED module H, up to category III

Dimensions in mm

DN	ISO	L	L1	L2	L3	H1	H4	H5	øE	øD	øD2	øD3	D4	øD5	øD6	D7	øD8	A	B	Ball bore	Weight in Kg		
																					CBS	CBSW	CBF CBG
5211		series 1																					
8	F03	65	20.4	65	-	10	30	7	45	-	25	36	M5	22	13.5	1/4"	14.2	9.5	5.4	11.1	0.6	0.6	-
10	F03	65	20.4	65	130	10	30	7	45	90	25	36	M5	22	17.2	3/8"	17.6	9.5	5.4	11.1	0.6	0.6	2.3
15	F03	65	20.4	65	130	10	30	7	45	95	25	36	M5	22	21.3	1/2"	21.8	9.5	5.4	11.1	0.6	0.6	2.4
20	F03	72.5	24.5	72.5	150	10	32	7	52	105	25	36	M5	22	26.9	3/4"	27.4	9.5	5.4	14.2	0.9	1	3.2
25	F04	85.4	31.4	85.4	160	15	38	12	60	115	30	42	M5	25	33.7	1"	34.2	11.1	7.5	20.6	1.4	1.6	4
32	F04	99.3	41.3	99.3	180	22	36	12	68	140	30	42	M5	25	42.4	1 1/4"	43	11.1	7.5	25.4	2	2.2	6.2
40	F05	110.4	48.4	110.4	200	29	42	16	76	150	35	50	M6	30	48.3	1 1/2"	49	14.3	8.9	31.7	3	3.1	7.8
50	F05	126.3	56.3	126.3	230	30	46	16	88	165	35	50	M6	30	60.3	2"	61.1	14.3	8.9	38	4.2	4.5	10.5

Notes

- All dimensions are related to reduced bore valves. For full bore valves please apply the dimensions of the next diameter (except L3, øD, øD6, D7 and øD8 which is identical in both instances)
- D dimensions are indicated for PN40. For other ratings please see EN 1092-1 or EN 1759-1
- For high pressure valves > DN50, please check RA data

Series EA

2 Piece cast ball valves with ISO top flange DN15 - DN150

Full bore, flanged version

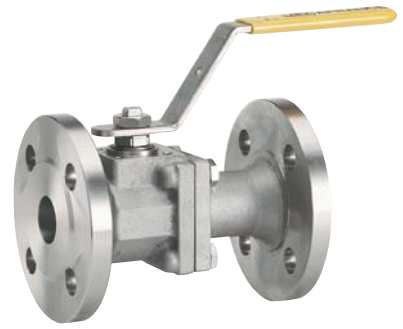

EA DN32 c/w, lockable handle

DN15 - DN40

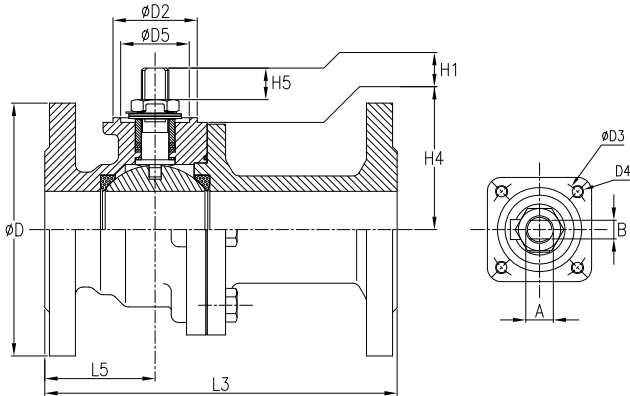

DN65 - DN100

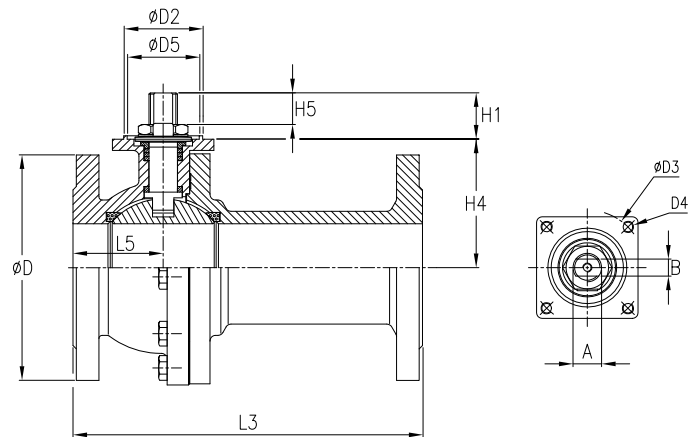

DN50

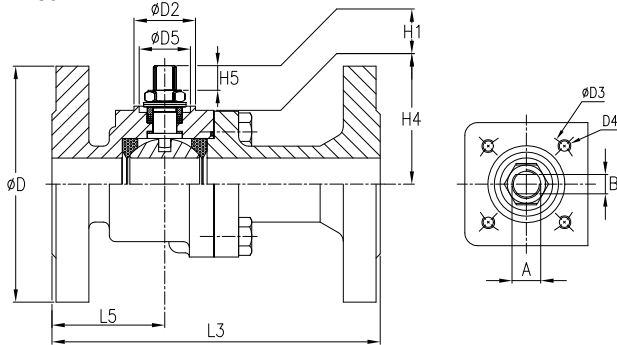

Approvals and certificates

- TA-Luft according VDI 2440
- CE: Module H, category III
- Lloyds register type approval
- DIN-GOST
- Standard: For PN10 - PN40 EN 1092-1 FTF Series 1, according EN 558
- Optional: Class 150 EN 1759-1 FTF series 3, according EN 558

- Optional: Class 300 EN 1759-1 FTF series 4, according EN 558
- Full bore
- Cast version
- Carbon and stainless steel trims

CE - PED module H, up to category III
 - TPED module H, up to category II

Dimensions in mm

DN	ISO	L3	L5	H1	H4	H5	øD	øD2	øD3	D4	øD5	A	B	Ball bore
5211 series 1														
15	F03	130	50	11	28	8.5	95	25	36	M5	22	9.5	5.4	14.2
20	F04	150	48.5	22	31	12	105	30	42	M5	25	11.1	7.5	20.6
25	F04	160	55	22	36	12	115	30	42	M5	25	11.1	7.5	25.4
32	F05	180	62	29	42	16	140	35	50	M6	30	14.3	8.9	31.7
40	F05	200	63	29.5	46.5	15.5	150	35	50	M6	30	14.3	8.9	38
50	F07	230	72	35.5	70	20.5	165	55	70	M8	45	18	8.9	50
65	F07	290	86.5	41	106	26.5	185	55	70	M8	45	25.4	18.9	62
80	F10	310	80	41	114	28	200	70	102	M10	64	25.4	18.9	78
100	F10	350	94	41	130	28	235	70	102	M10	64	25.4	18.9	98
150	F12	480	160	72	163.5	42	300	85	125	M12	65	35	28.5	150

Series ES and EM

2 Piece forged ball valves with ISO top flange DN15 - DN150
 Full bore, flanged and butt weld version
 (Series EM in cast version)

ES DN150, flanged

ES DN100, butt weld

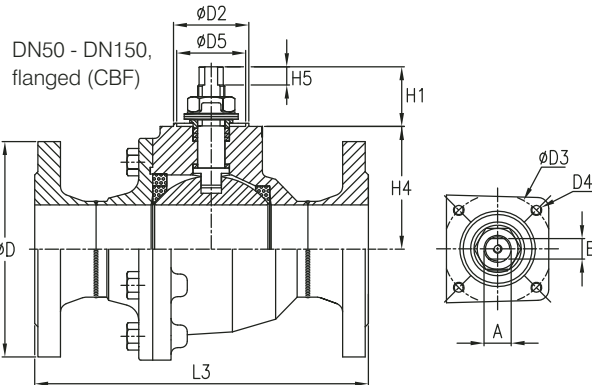
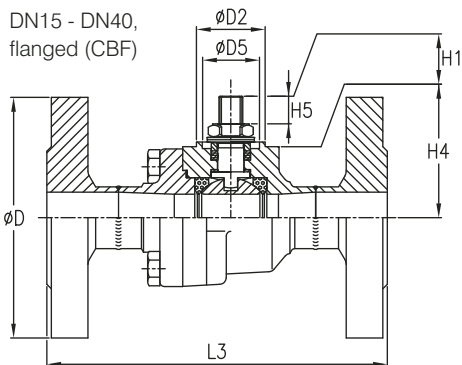
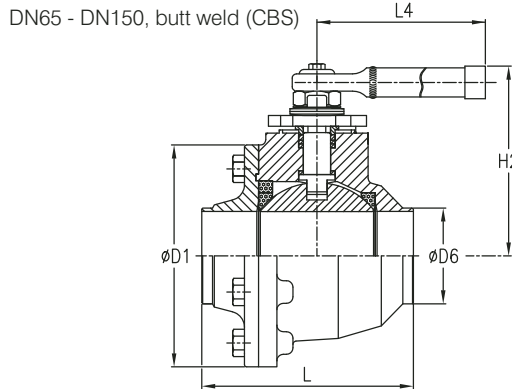
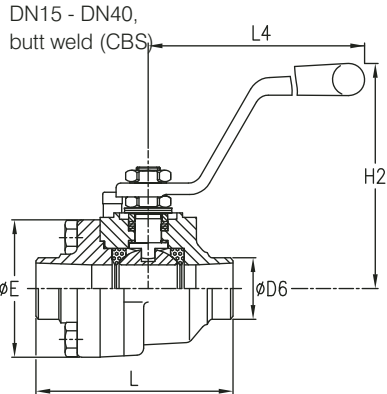
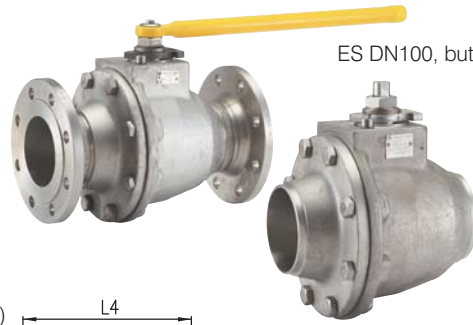

Approvals and certificates

- TA-Luft according VDI 2440
- CE: Module H, category III
- Fire tested according BS 6755 Part II (series ES)
- Lloyds register type approval
- DIN-GOST
- Standard: for PN10 - PN40 EN 1092-1 FTF Series 1, according EN 558
- Optional ES only: Class 150 EN 1759-1 FTF series 1,3 or 12, according EN 558
- Optional ES only: Class 300 EN 1759-1 FTF series 4, according EN 558
- Full bore
- Forged version (series ES), cast version (series EM)
- Carbon steel and stainless steel trims
- For socket welded and threaded ends please contact MECAFRANCE representative
- Pressure range: PN10 - PN100, ANSI 150/300 (series ES)
- Temperature range: -40°C to +400°C; -196°C to +80°C cryogenic version

CE - PED module H, up to category III
 - TPED module H, up to category II

Dimensions in mm

DN	ISO	L	L3	L4	H1	H2	H4	H5	ØE	ØD	ØD1	ØD2	ØD3	D4	ØD5	ØD6	A	B	Weight in Kg		
																			Ball bore	CBS (series ES)	CBF
			series 1							PN10 to 40											
15	F03	75	130	140	10.5	91	28	8.5	52	95	-	25	36	M5	22	21.3	9.5	5.4	14.2	1.3	2.4
20	F04	86	150	180	22	110	31	12	60	105	-	30	42	M5	25	26.9	11.1	7.5	20.6	1.7	3.4
25	F04	92	160	180	22	115	36	12	68	115	-	30	42	M5	25	33.7	11.1	7.5	25.4	2	4.2
32	F05	104	180	200	29	135	42	16	76	140	-	35	50	M6	30	42.4	14.3	8.9	31.7	2.5	5.5
40	F05	120	200	200	29.5	140	46.5	16	88	150	-	35	50	M6	30	48.3	14.3	8.9	38	4.3	8.6
50	F07	138	230	250	16	155	70	16	-	165	137.5	55	70	M8	45	60.3	14.3	8.9	50	6.9	12
65	F07	160	290	480	54	161	99	17	-	185	165	55	70	M8	45	76.1	22.5	19	62	8	15
80	F10	196.5	310	480	54	176	114	17	-	200	206	70	102	M10	64	88.9	22.5	19	82.4	21.2	29.5
100	F10	246	350	480	54	190	128	17	-	220	234	70	102	M10	64	114.3	22.5	19	100	28.2	40
150	F12	269	480	720	71.5	262	163.5	28	-	285	310	85	125	M12	65	168.3	35	28.5	150	70	95

Valves with single heating jacket

3 Piece ball valves with ISO top flange DN8 - DN200

(Series CA for DN15 - DN50, Series RA for DN65 - DN200)

Double flanged, butt weld version with heating jacket on body section

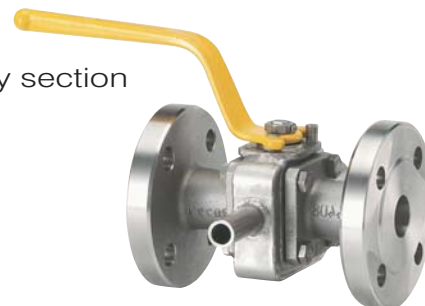

RA DN25, flanged,
single jacket

Series CA DN32 - DN50, butt weld

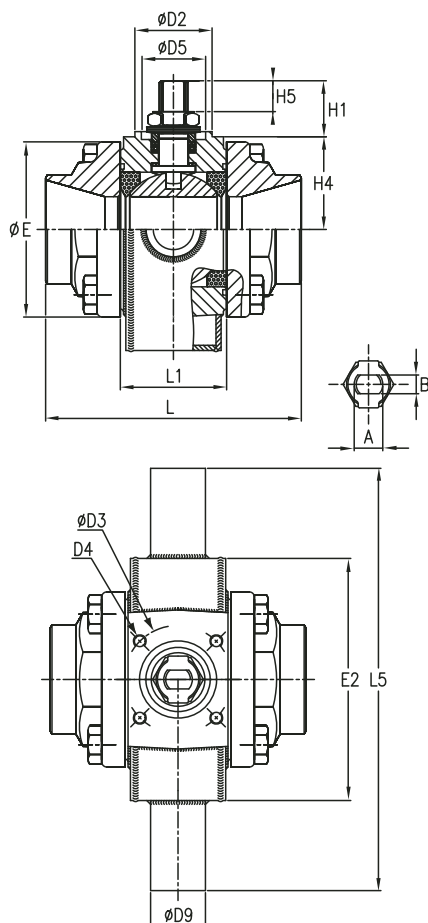

Series RA, DN100 - DN200, butt weld

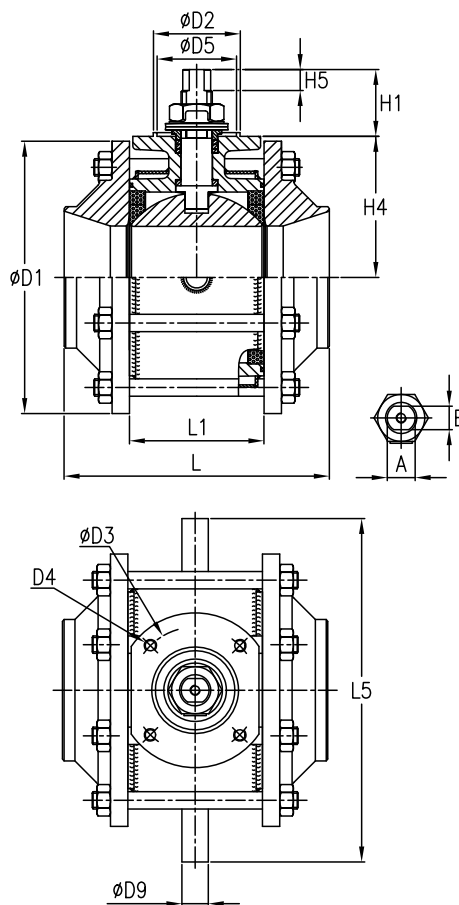

Technical details

- Stainless steel versions only
- For further details on end connections and top flange variations, see valve details Series CA and RA
- Optional metal seated version for high temperature and abrasive applications
- For jacketed 2 piece ball valves please contact your local MECAFRANCE representative
- Jacket parameters: standard PN10 rating, optional PN20, maximum temperature 200°C
- Tracing with steam, thermal oil or hot water
- Optional jacket connections are screwed, flanged, welding neck or butt weld

CE - PED module H, up to category III
- TPED module H, up to category III

Dimensions in mm

DN	ISO	L	L1	L5	H1	H4	H5	øE	E2	øD1	øD2	øD3	D4	øD5	øD9	A	B	Ball bore
5211																		
8	F03	65	20.4	112	10	30	7	45	62	-	25	36	M5	22	13.5	9.5	5.4	11.1
10	F03	65	20.4	112	10	30	7	45	62	-	25	36	M5	22	13.5	9.5	5.4	11.1
15	F03	65	20.4	112	10	30	7	45	62	-	25	36	M5	22	13.5	9.5	5.4	11.1
20	F03	72.5	24.5	127	10	32	7	52	77	-	25	36	M5	22	13.5	9.5	5.4	14.2
25	F04	85.4	31.4	184	15	38	12	60	84	-	30	42	M5	25	17.2	11.1	7.5	20.6
32	F04	99.3	41.3	194	22	36	12	68	94	-	30	42	M5	25	21.3	11.1	7.5	25.4
40	F05	110.4	48.4	202	29	42	16	76	102	-	35	50	M6	30	21.3	14.3	8.9	31.7
50	F05	126.3	56.3	224	30	46	16	88	114	-	35	50	M6	30	21.3	14.3	8.9	38
65	F07	142.6	71.4	214	16	70	16	-	-	143	55	70	M8	45	21.3	14.3	8.9	50
80	F07	169.5	88.9	245	54	99	17	-	-	165	55	70	M8	45	21.3	22.5	19	62
100	F10	214	108.5	277.5	54	114	17	-	-	206	70	102	M10	64	21.3	22.5	19	82.4
125	F10	277	134.6	308	54	128	17	-	-	234	70	102	M10	64	21.3	22.5	19	100
150	F10	307	134.6	308	54	128	17	-	-	234	70	102	M10	64	21.3	22.5	19	100
200	F12	409	189.1	302	72	186	28	-	-	345	85	125	M12	65	21.3	35	28.5	150

Valves with 3 piece heating jacket

3 Piece ball valves with ISO top flange DN10 - DN200
 (Series CA for DN15 - DN50, Series RA for DN65 - DN200)
 Heating jacket on body and end connections
 Flanged version

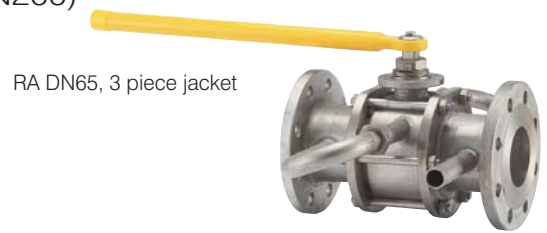

DN32 - DN50

DN80 - DN200

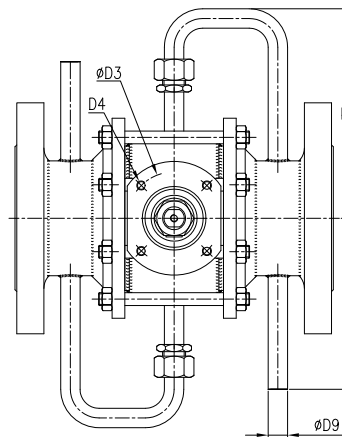
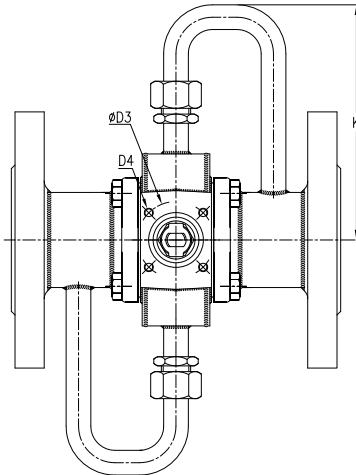
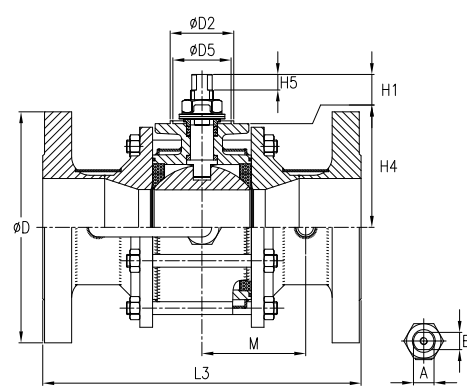
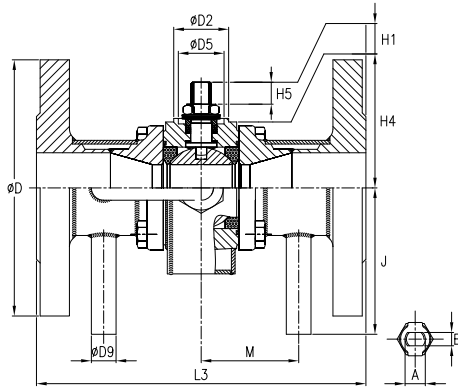

Technical details

- Stainless steel versions only
- For further details on end connections and top flange variations, see valve details Series CA and RA
- Optional metal seated version for high temperature and/or abrasive applications
- For jacketed 2 piece ball valves please contact your local MECAFRANCE representative
- Jacket parameters: standard PN10 rating, optional ANSI 150, maximum temperature 200°C
- Tracing with steam, thermal oil or hot water
- Optional jacket connection are screwed, flanged, welding neck or butt weld

CE - PED module H, up to category III
 - TPED module H, up to category III

Dimensions in mm

DN	ISO	L3	M	J	K	H1	H4	H5	ϕD	$\phi D2$	$\phi D3$	D4	$\phi D5$	$\phi D9$	A	B	Ball bore
	5211 series 1								(PN16)								
10	F03	130	33	55	115	10	30	7	90	25	36	M5	22	10.2	9.5	5.4	11.1
15	F03	130	33	60	115	10	30	7	95	25	36	M5	22	13.5	9.5	5.4	11.1
20	F03	150	38	65	120	10	32	7	105	25	36	M5	22	13.5	9.5	5.4	14.2
25	F04	160	44	70	125	15	38	12	115	30	42	M5	25	13.5	11.1	7.5	20.6
32	F04	180	51	80	145	22	36	12	140	30	42	M5	25	13.5	11.1	7.5	25.4
40	F05	200	58	85	150	29	42	16	150	35	50	M6	30	13.5	14.3	8.9	31.7
50	F05	230	67	95	160	30	46	16	165	35	50	M6	30	13.5	14.3	8.9	38
65	F07	290	85	105	150	16	70	16	185	55	70	M8	45	21.3	14.3	8.9	50
80	F07	310	95	110	160	54	99	17	200	55	70	M8	45	21.3	22.5	19	62
100	F10	350	110	120	180	54	114	17	220	70	102	M10	64	21.3	22.5	19	82.4
125	F10	400	130	135	200	54	128	17	250	70	102	M10	64	21.3	22.5	19	100
150	F10	480	150	155	200	54	128	17	285	70	102	M10	64	21.3	22.5	19	100
200	F12	600	190	180	240	72	186	28	340	85	125	M12	65	21.3	35	28.5	150

Metal seated

2 and 3 Piece ball valves DN15 - DN200 Full Bore / DN20 - DN250 Reduced Bore

EA 66 CBF DN40 metal sealing system

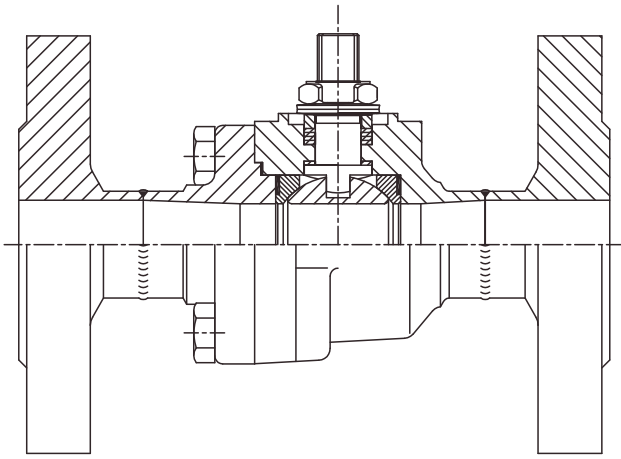
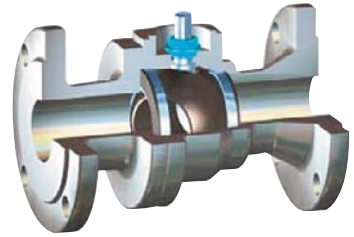

ES DN40 with metal seats

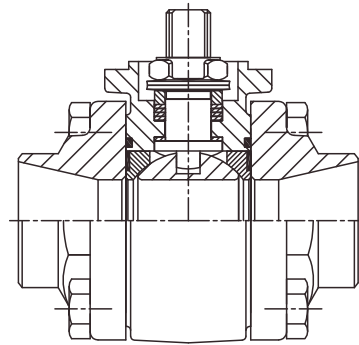

RA DN40 with metal seats

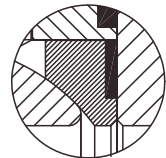

Metal seat type

MECAFRANCE metal sealing system and the graphite sealing systems are fully interchangeable with the standard PTFE systems of the valve series R, RA, CA, EA and ES. No further modifications to the valve body or ends pieces are required making these designs extremely versatile.

Metal sealing system:

For the metal sealing system Tungsten Carbides are sprayed with ultrasonic speeds, in cold condition, on the surfaces of the ball and seats. As no catalysts or additives are applied the surface layer is of a 100% homogeneous structure, resulting in an optimum protection of the under laying materials. Seats and ball are then ground, polished and lapped for a perfect match. Ball and seats are a complete set and do not have to be exchanged by an other ball or seats. The seats are loaded with graphite Belleville washers ensuring a bi-directional tight shut off performance.

This unique, high quality sealing system can be applied on all abrasive applications such as granulate transport, water glass, PTFE powder transport, pulp handling, polymerizing MMA, phosphate powder transport, French fries production, sugar beet handling, and wet steam.

Metal seated

2 and 3 Piece ball valves DN15 - DN200 Full Bore / DN20 - DN250 Reduced Bore

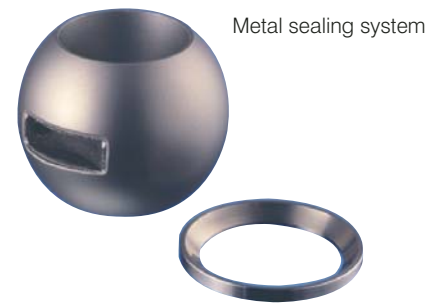

Technical details

- For dimensional details refer to R, RA, EA, ES and CA valves with carbon and metal sealing systems
- Stainless steel and carbon steel bodies
- Metal sealing system:
 - Titanium stabilized stainless steel ball and seats (DIN 1.4571)
 - Tungsten Carbide layers applied on ball and seat surfaces
 - Seats are axially compressed with graphite washers
 - Maximum temperature: 400°C (for higher temperatures contact your local MECAFRANCE representative)
 - Maximum pressure rating: PN40 in function of temperature and valve size
 - Bi-directional gas tight shut off performance due to optional lapping process
 - Can be installed in standard MECAFRANCE ball valves: No modifications required
 - Excellent chemical and abrasion resistance
- The unique sealing system can be installed in all standard MECAFRANCE 2 piece and 3 piece ball valves without modifying the end pieces or body. In this way standard PTFE seats can be replaced with this solution.

Metal Seat

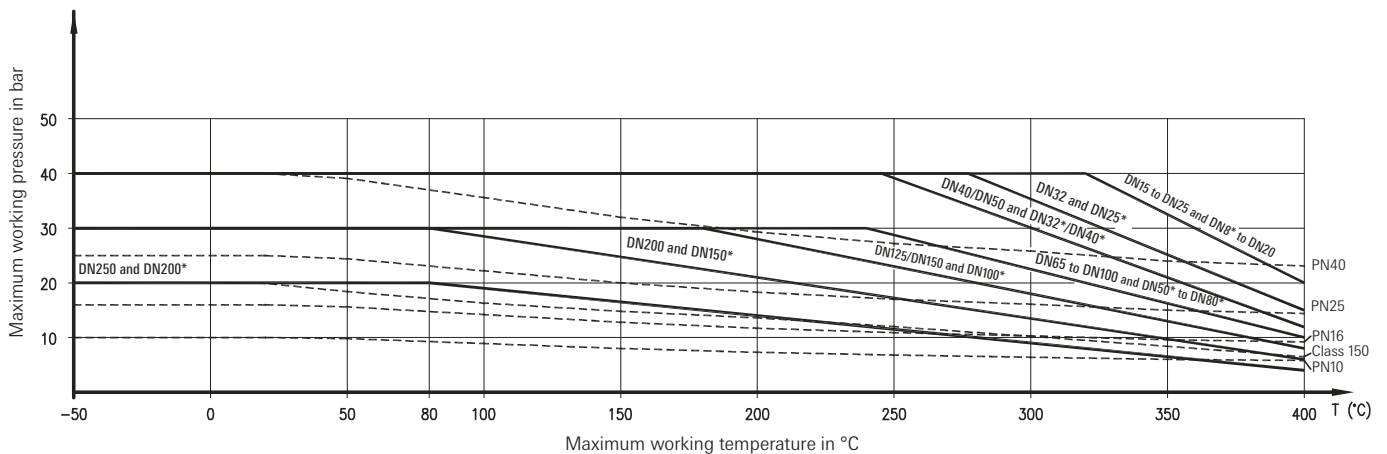

Notes

- * Full bore
- Please always verify maximum body ratings as each above mentioned diagram presents data for the seat material only
- For other material options, please contact your nearest MECAFRANCE representative

Cryogenic valves DN8 - DN50

3 Piece ball valves with ISO top flange, series CA-CRYO
Butt weld, threaded, socket weld and flanged version



CA 66 CBS DN25

CA 66 CBS DN25

DN8 - DN25

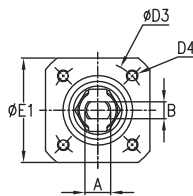
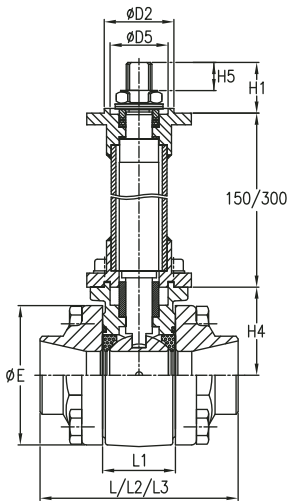

DN32 - DN50

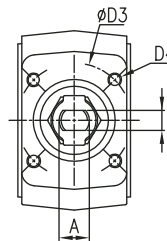
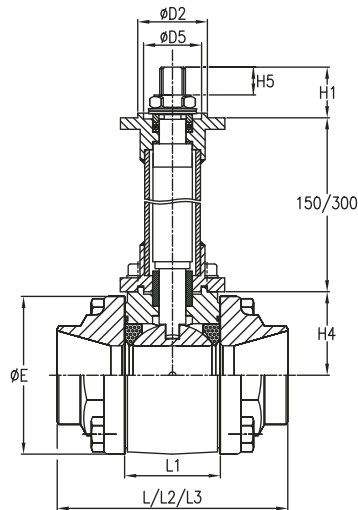

Available end connection options:

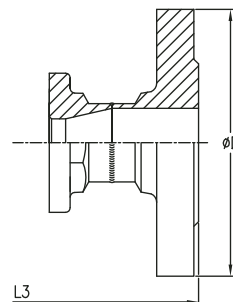
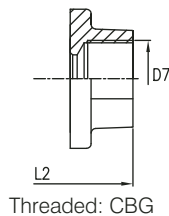
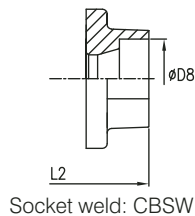
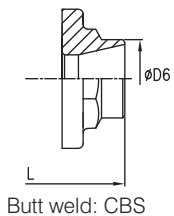

Design features

- Reduced and full bore options available
- Stainless steel trim
- Forged end connections
- Integrated ISO 5211 top flange for easy automation
- Wide variety of seat material options available
- Temperature range: -196°C to + 80°C
- Pressure balancing hole in upstream side of the ball
- Scalloped seat design
- DN15 - DN65 in compliance with EN 1626 (on request)
- Spindle extensions to be mounted uniquely vertically
- Pressure rating: maximum PN100 in function of valve size and seat material selection
- Valve design according EN 13445
- Valves are degreased according EN 12300
- Valves are individually packed in polyethylene bags
- Size range: DN15 - DN50: CA version
DN65 - DN150: RA version

Dimensions in mm

DN	ISO	L	L1	L2	L3	H1	H4	H5	ϕE	$\phi E1$	ϕD	$\phi D2$	$\phi D3$	D4	$\phi D5$	$\phi D6$	D7	$\phi D8$	A	B	Ball bore
5211		series 1																			
8	F03	65	20.4	65	-	10.5	30	7	45	45	-	25	36	M5	22	13.5	1/4"	14.2	9.5	5.4	11.1
10	F03	65	20.4	65	130	10.5	30	7	45	45	90	25	36	M5	22	17.2	3/8"	17.6	9.5	5.4	11.1
15	F03	65	20.4	65	130	10.5	30	7	45	45	95	25	36	M5	22	21.3	1/2"	21.8	9.5	5.4	11.1
20	F03	72.5	24.5	72.5	150	10.5	32	7	52	45	105	25	36	M5	22	26.9	3/4"	27.4	9.5	5.4	14.2
25	F04	85.4	31.4	85.4	160	22	38	12	60	45	115	30	42	M5	25	33.7	1"	34.2	11.1	7.5	20.6
32	F04	99.3	41.3	99.3	180	22	36	12	68	45	140	30	42	M5	25	42.4	1 1/4"	43	11.1	7.5	25.4
40	F05	110.4	48.4	110.4	200	29	42	16.5	76	52	150	35	50	M6	30	48.3	1 1/2"	49	14.3	8.9	31.7
50	F05	126.3	56.3	126.3	230	29	46	16.5	88	52	165	35	50	M6	30	60.3	2"	61.1	14.3	8.9	38

Notes

- All dimensions are related to reduced bore valves. For full bore valves please apply the dimensions of the next diameter (except L3, ϕD , $\phi D6$, D7 and $\phi D8$ which is identical in both instances)

Micro-Clean

3 Piece ball valves with ISO top flange DN8 - DN200

For hygienic and sanitary applications



R DN25, CBK Tri-Clamp

RA66 DN25, CBK Tri-Clamp
with extension and round
handwheel

Series RA, reduced bore,
CBS butt weld

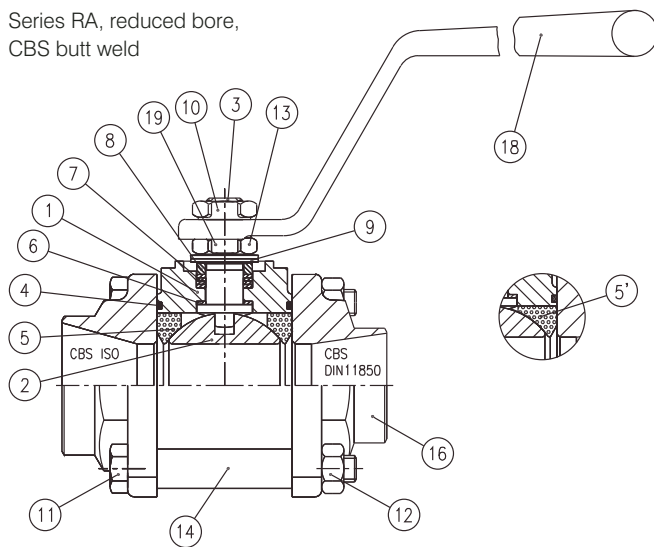

Series RA, full bore,
OD tubing for orbital welding

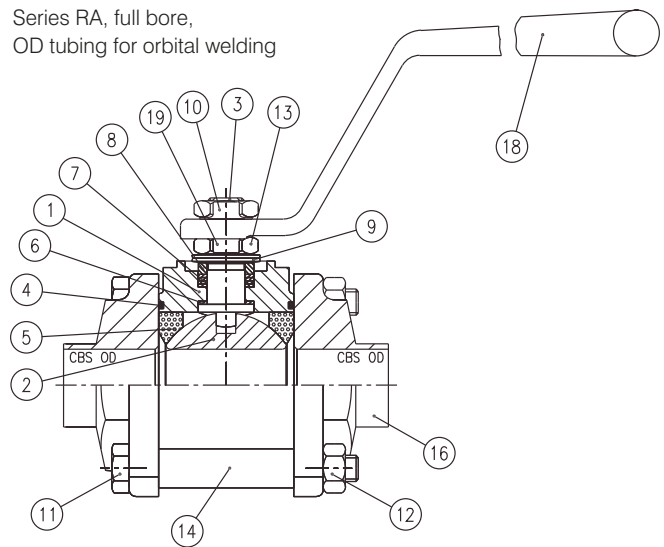

Design features

- For dimensional details, see series RA
- Valves are degreased according EN 12300
- Valves are individually packed in polyethylene bags
- Electro-polished internal/external surface (optional)
- Forged body material up to DN32
- Cavity fillers (optional)
- External polishing (optional)
- FDA approval on components

Applications

- Pharmacy
- Biotechnology
- Photomechanical industry
- Food industry
- Manufacturing of microchips
- Beverage

CE - PED module H, up to category III
- TPED module H, up to category III

Parts list

Parts no.	Description	Ball valve	Standard version	Micro-Clean version
			Standard processing	
1	Body	Body, internal	3,2 - 6,3 μm	0,8 μm
2	Ball	Ball, internal	3,2 - 6,3 μm	0,8 μm
3	Stem	Ball, external	0,4 μm	0,4 μm
4	Body gasket			
5	Seat	Butt weld end	3,2 - 6,3 μm	0,8 μm
5'	Cavity filler			
6	Stem seal			
7	Stem packing			
8	Stem packing follower			
9	Belleville washer			
10	Lock washer			
11	Body screw			
12	Nut			
13	Stem Nut			
14	Sleeve			
16	Butt weld end			
18	Handle			
19	Lock washer			

Microclean

3 Piece ball valves with ISO top flange DN8 - DN200

For hygienic and sanitary applications

This unique MECAFRANCE ball valve range is extremely suitable for sanitary and hygienic applications as its construction can be fully cleaned.

The surface cleaning is guaranteed as the Micro-Clean's internal surfaces of the ball, body and the ends are mechanically machined and polished (upon request down to $0.2\ \mu$). After the polishing these components are electro-polished. This refined process does smoothen the shape of the surface so that potential pollutions or sources for contamination can not get trapped in the surface.

The picture below clearly explain the advantages of the electro-polishing process.

The internal cavity cleaning is obtained either by applying external CIP nipples, or by using the unique and patented MECAFRANCE IPC technology as described elsewhere in this brochure. In addition, cavity fillers are installed on request, thus reducing the "dead area" inside the valves to an absolute minimum (the number of fillers varies per valve type and size).

Micro-Clean valves can be provided with most common flange ends, but also with Tri-Clamps connections, or extended OD-tubing for orbital welding robots.

After assembly and testing, all Micro-Clean valves are degreased according EN 1300 and wrapped individually in polyethylene bags.

Micro-Clean valves are applied worldwide successfully into the food and beverage industry, and into numerous pharmaceutical and biotechnological applications.

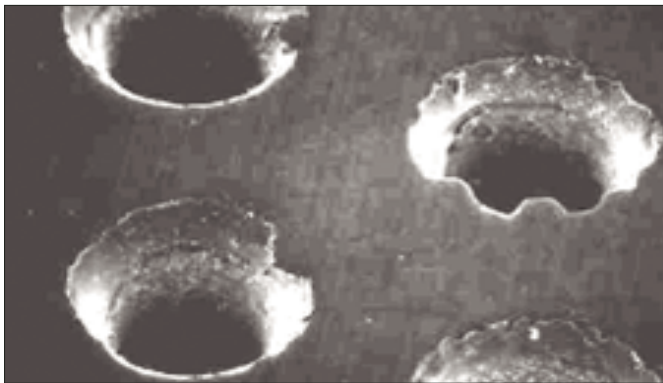

Mechanically machined surface

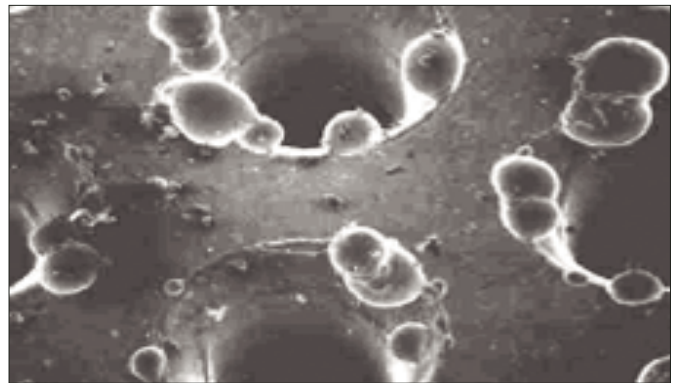

Bacteriological polluted surface

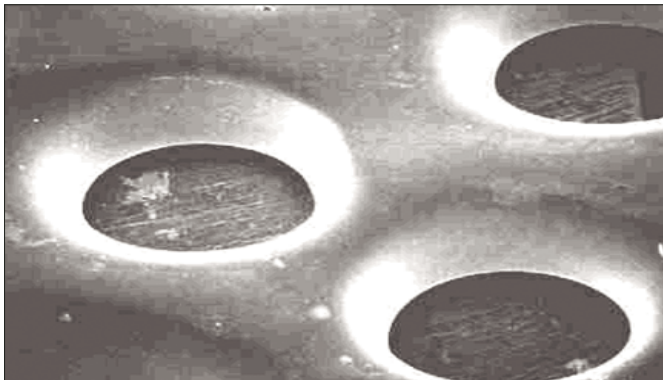

Electro-polished surface



Before the electro polishing

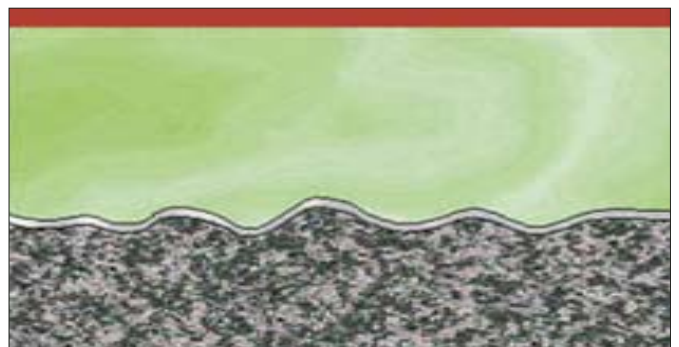

After the electro polishing

IPC valve (In Place Cleaning)

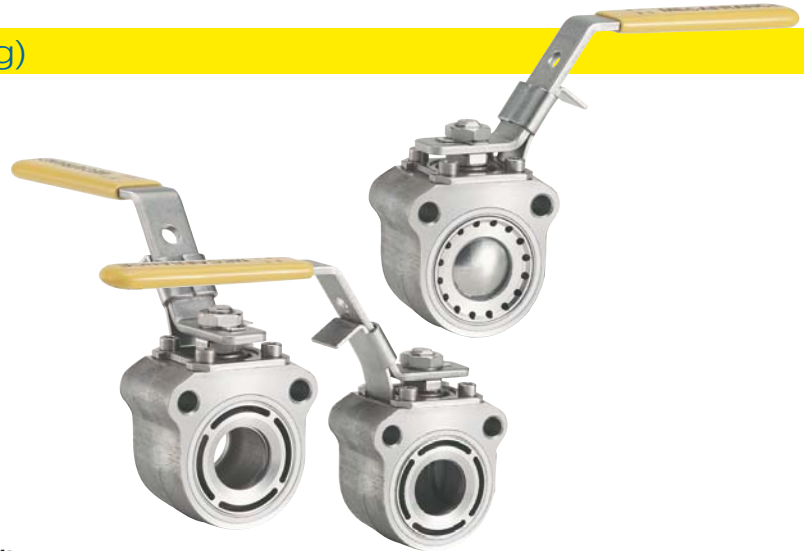

Schematic overview of the IPC valve functionality

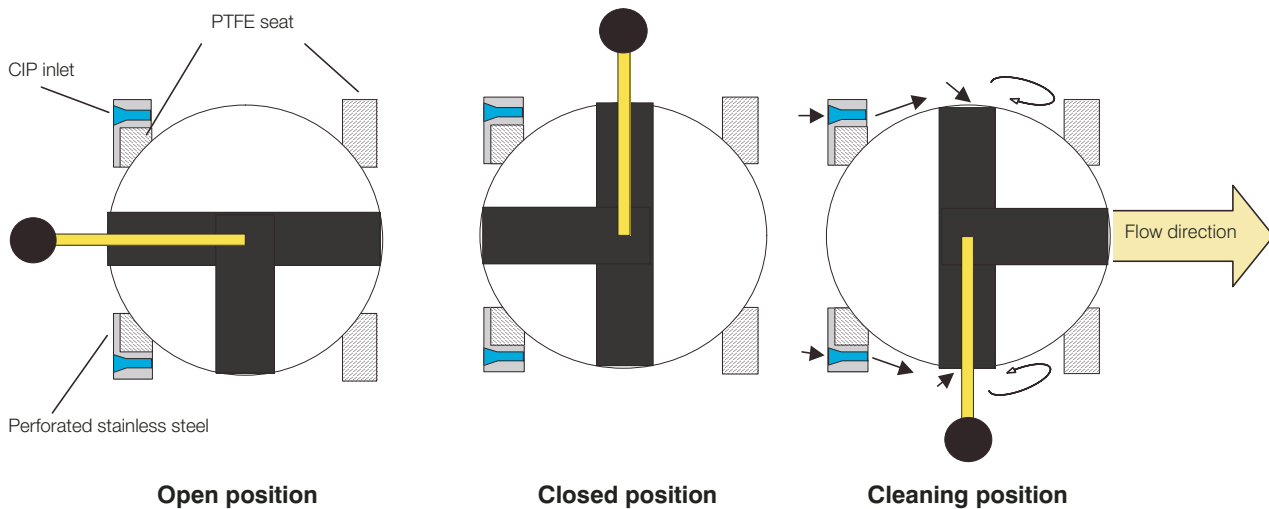

(Valves shown with end pieces removed)

Design features

- CIP cleaning whilst the valve is still installed inline
- No external CIP ports required
- No secondary CIP lines required
- Slotted CIP holes for larger flow available
- Suitable for actuation (180 degree rotation)
- Threaded ends: CBG according ISO 228-1, CBG conical according ISO 7 and NPT according ANSI B 1.20
- Socket weld (CBSW): Female socket weld ANSI B16.11
- Butt weld (CBS): ISO, DIN, ASME, OD, extended OD
- Flanged (CBF): Cast and forged design EN 1092-1, EN 1759-1. Standard FTF according EN 558
- Design codes: DIN 3840
- DN8 - DN32: Forged bodies. Larger sizes in cast body material
- Special end connections are available on request
- Pressure range: PN10 - PN100, mono-directional
- Temperature range: -40°C to +200°C
- Full bore (true-tube on request)
- Stainless steel

Applications

- Food and beverage
- Pharmaceutical
- In general where in-line cleaning is mandatory



(Valve shown with end piece removed)

True-Tube™

A natural extension of our standard Micro-Clean design is the MECAFRANCE True-Tube™ range. This range is designed in accordance with ASME BPE-1997, Bio processing equipment. Being a truly straight through design, the True-Tube™ range is the ultimate choice to reduce the risk of product contamination and/or pressure drops. The internal dimension of the tube type end pieces are the same. There are no lips or crevices to harbour harmful media deposits. The tube butt weld ends have a sulphur content between 0.005% and 0.017% ensuring weld quality to comparable tubing. Manual or automated, MECAFRANCE Micro-Clean ball valves provide reliable, contaminate free, flow control in the high purity gases, fluids and vacuum services, biotechnological applications.

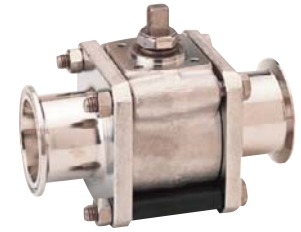

Details and options

Details and options		Code
o Port	- True-Tube (Port ID of the valve matches the ID of the SS OD tubing)	T/T
o Internal surface finish designation	- 25 µin / 0.625 µm R _a - 20 µin / 0.5 µm R _a (optional/on request) - 15 µin / 0.375 µm R _a (optional/on request)	V3 V2 V1
o Body and end pieces	- Bodies DN10 - DN50 (NPS 1/2 to NPS 2) DIN 1.4404 (A182-316L) - Bodies DN65 - DN100 (NPS 2 1/2 - NPS 4) DIN 1.4408 (A351-CF8M)	6 6
o Ball and stem	- DIN 1.4404 (316L)	6
o Seats	- Virgin PTFE - Reinforced PTFE - TF-4215® enhanced 25% carbon filled PTFE - UHMWPE	TF TE HT UU
o Body seals	- Virgin PTFE - UHMWPE - TF-4215® enhanced 25% carbon filled PTFE	T U H
o End connections	- O.D. tube (SS) extended length for automatic/orbital welding DN15 - DN80 (NPS 1/2 to NPS 3) OD tube WT = 1.65 mm (0.065"), DN100 (NPS 4) OD tube WT = 2.1 mm (0.083") - Tri-Clamp style	TBX KCE
o Valve body style/design (standard feature)	- ISO 5211 flange and bolting pattern design	I
o Handle Options	- SS lever handle (except for DN65 (NPS 2 1/2) and larger valves, H - CS pipe lever handle) - SS oval handle (for DN40 (NPS 1 1/2) and smaller valves) - SS round handle (for DN40 (NPS 1 1/2) and smaller valves) - SS latch locking handle (for DN50 (NPS 2) and smaller valves) - Gear operator (recommended for DN100 (NPS 4) valves)	H O R L G

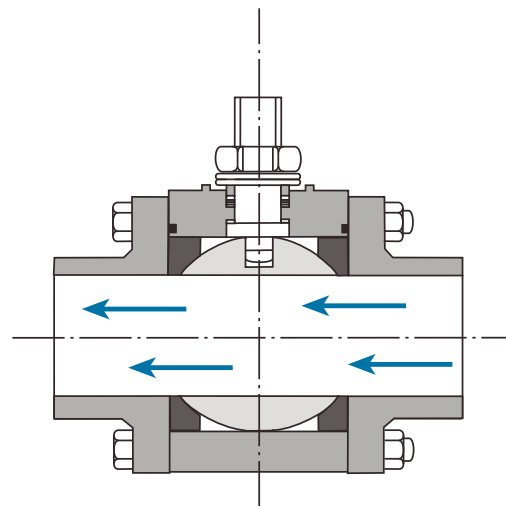

3-Way valves

3 Piece ball valves with ISO top flange DN8 - DN200

Ball with L-bore

Horizontal center connection
90° rotation

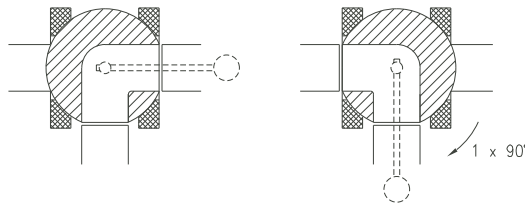

Ball with L-bore

Vertical center connection
90° rotation

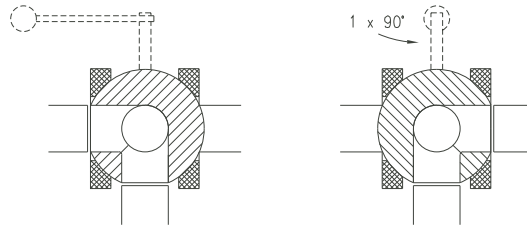

Ball with L-bore

Vertical center connection
180° rotation

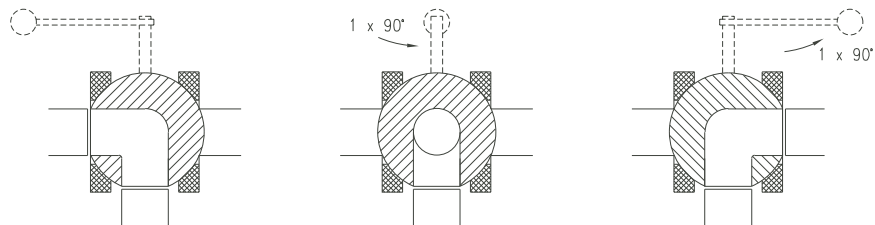

Ball with T-bore

Horizontal center connection
180° rotation

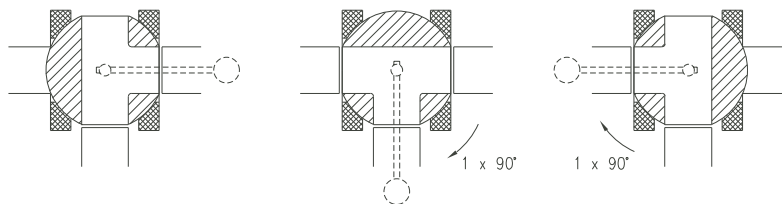

Ball with T-bore

Vertical center connection
180° rotation

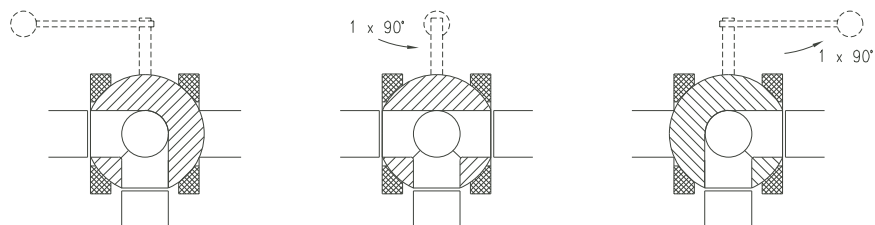

Design features

- Maximum differential pressure = 6 bar
- Carbon steel and stainless steel trims
- Not seated center connection of the ball. In case of T-bores the medium can flow around the ball and can exit through the center connection. The third way will not be tightened.
- For valve details: See R, RA and CA pages

CE - PED module H, up to category III
 - TPED module H, up to category II

Ordering example

Typ 3 6 L H 4 1 1

- Side connection type left (see code below)
- Side connection type right (see code below)
- Centre connection type (see code below)
- Position of centre connection (H = horizontal; V = vertical)
- Ball bore (L = L-shaped; T = T-shaped)
- Material (5 = carbon steel; 6 = stainless steel)
- Series (3 = three-way version)

Code for connection type

- 1 = weld ends
- 2 = female thread according to DIN 2999
- 3 = NPT female thread
- 4 = flange connection

3-Way valves

3 Piece ball valves with ISO top flange DN8 - DN150

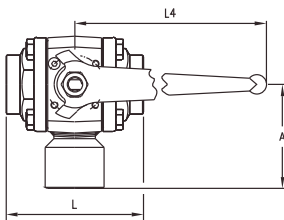
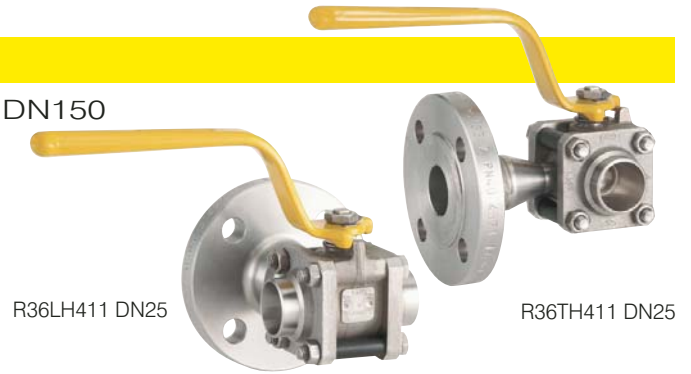

DN15 - DN200
Butt weld side connections
and center connection

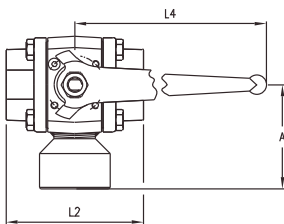
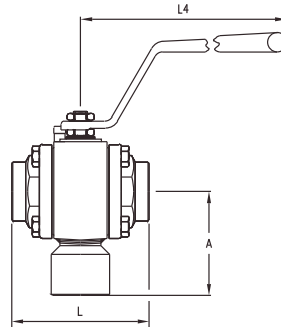

DN15 - DN100
Threaded side connections
and socket weld
center connection

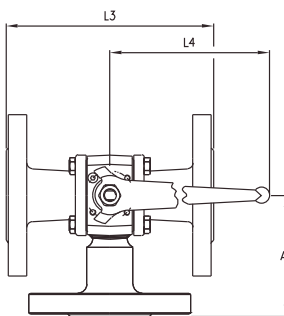
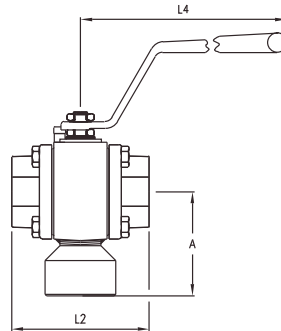

DN15 - DN200
Flanged side connections
and center connection

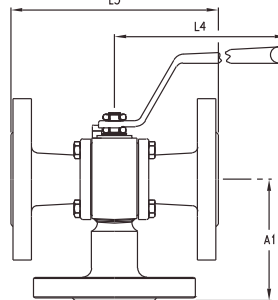

**Horizontal connection
(top view)**

**Vertical connection
(side view)**
(Body shown for DN15 - DN50)

Dimensions in mm

DN	A	A1	L	L2	L3	L4	Ball bore	Inside diameter of center connection
8	54	-	65	65	-	140	11.1	10
10	54	90	65	65	130	140	11.1	10
15	54	90	65	65	130	140	11.1	10
20	64	95	72.5	72.5	150	140	14.2	12
25	64	100	85.4	85.4	160	180	20.6	18
32	75	105	99.3	99.3	180	180	25.4	25
40	80	115	110.4	110.4	200	200	31.7	30
50	90	125	126.3	126.3	230	200	38	35
65	115	145	142.6	160	290	250	50	35 [1]
80	175	155	169.5	180	310	480	62	62
100	210	175	214	214	350	480	82.4	82
125	-	240	277	-	400	480	100	96
150	-	240	307	-	480	480	100	96

Notes

- All dimensions are related to reduced bore valves. For full bore valves please apply the dimensions of the next diameter (except L3, which is identical in both instances)
- [1] 45 on request

Tank bottom valves

3 Piece ball valves with ISO top flange DN15 - DN150
Full Bore only



RA DN40, CBFC/CBS

DN50, full bore

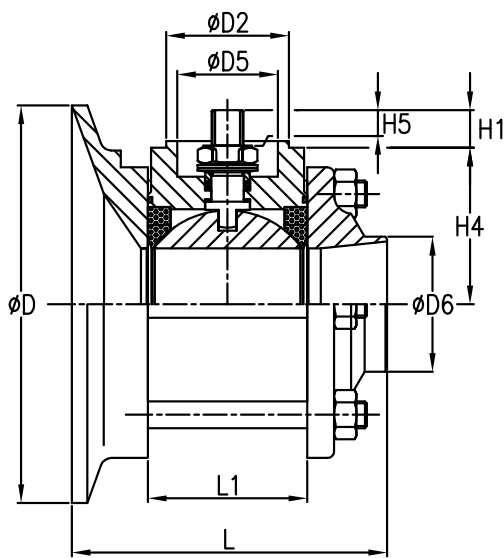

Type indication: CBFC/CBS

DN65 - DN150, full bore

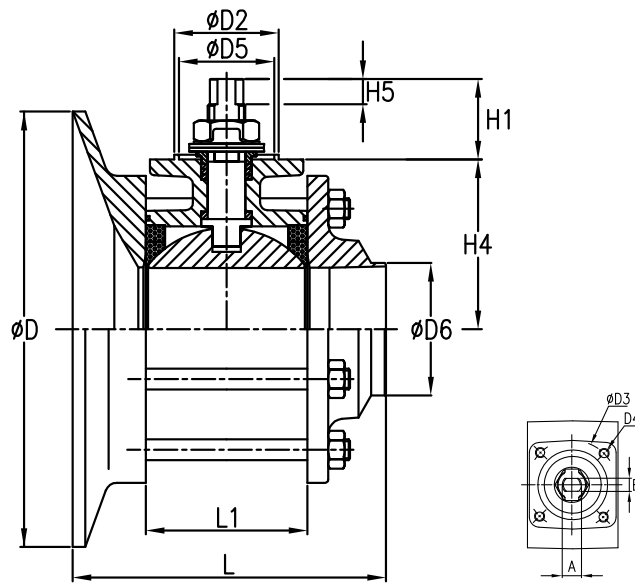

Type indication: CBFC/CBS

Design features

- Size range: DN15 - DN150
- Temperature: -40°C - +280°C
- Inlet: weld-in flange, outlet butt/socket weld, threaded or flanged
- Stainless steel trim
- Optional internal/external polishing
- Unobstructed flow
- For other dimensional details, see Series RA
- Full bore version only

Applications

- Tanks and tankers
- Container constructions
- IBC's
- Commercial construction

CE - PED module H, up to category III
- TPED module H, up to category II

Dimensions in mm

DN	ISO	L	L1	H1	H4	H5	ϕD	$\phi D2$	$\phi D3$	D4	$\phi D5$	$\phi D6$	A	B	Ball bore
15	F03	72.5	24.5	10	32	7	95	25	36	M5	22	21.3	9.5	5.4	14.2
20	F04	83.4	31.4	15	38	12	110	30	42	M5	25	26.9	11.1	7.5	20.6
25	F04	90.3	41.3	22	36	12	95	30	42	M5	25	33.7	11.1	7.5	25.4
32	F05	122.4	48.4	29	42	16	139.7	35	50	M6	30	42.4	14.3	8.9	31.7
40	F05	126.3	56.3	30	46	16	139.7	35	50	M6	30	48.3	14.3	8.9	38
50	F07	141	71.4	16	70	16	177.8	55	70	M8	45	60.3	14.3	8.9	50
65	F07	171.3	88.9	54	99	17	249	55	70	M8	45	76.1	22.5	19	62
80	F10	210.2	108.5	54	114	17	292	70	102	M10	64	88.9	22.5	19	82.4
100	F10	256.8	134.6	54	128	17	330	70	102	M10	64	114.3	22.5	19	100
150	F12	350.1	189.1	72	186	28	381	85	125	M12	65	168.3	35	28.5	150

Notes

- All dimensions are related to reduced bore valves. For full bore valves please apply the dimensions of the next diameter (except ϕD and $\phi D6$ which is identical in both instances)

Secondary containment unit

This bolt-in secondary shaft sealing unit can be bolted directly on all Mecafrance Series RA, CA, ES, EM and EA valves. In this way, the primary shaft sealing can be monitored.

Features

- No modifications are needed
- Secondary shaft seal (1)
- Supporting ring (2)
- Robust stainless steel housing (3)
- Exact centering feature thru spigot (4)
- Additional PTFE sealing (5)
- Optional leak detection port (6)
- One piece stainless steel shaft (7)
- ISO 5211 top flange (9)

Advantages

- No product leakage, nor spillage
- Increased plant and environment safety
- In compliance with current and future government regulations

Valves are in compliance with TA-Luft and Clean Air Acts

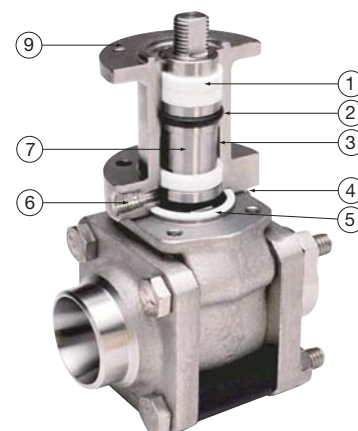

Size range series RA, CA, ES, EM, EA: DN8 - DN150

Spring return handle ('Dead man's lever')

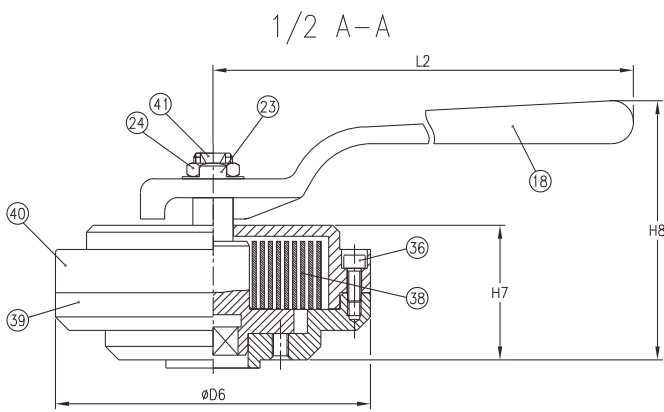
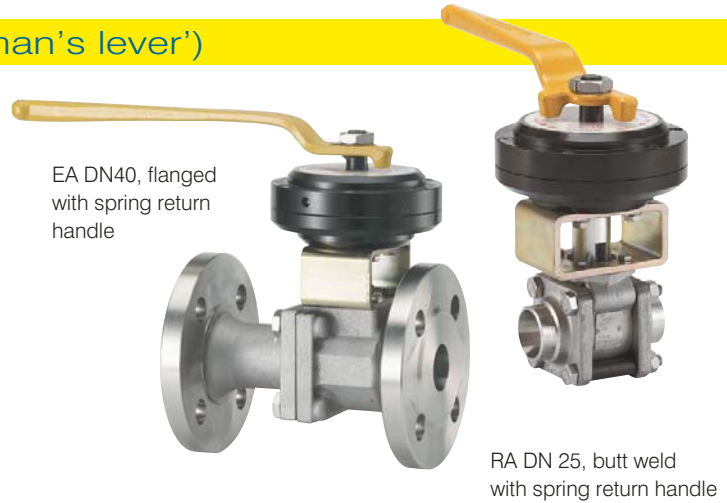

Connection details

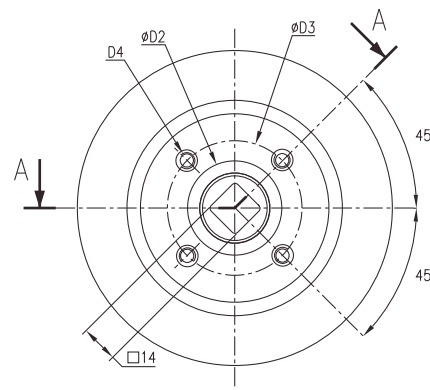

Type indication: BHM

Design features

- Action: Spring-to-Open, Spring-to-Close
- Double inside stop avoids risk on injury
- Maintenance free due to internal grease filling
- Compact, closed housing guaranteeing functionality
- To be mounted on RA, CA, EA and ES valves
- ISO interface enabling standard mounting kits
- Maximum valve size: DN50 reduced bore, and DN40 full bore (PTFE or RTFE seats)

Applications

- Safety device
- Loading and unloading of dangerous media
- To avoid unintentional use of the valve
- All valves which are operated only for short period of time

Advantages of the spring return handle

- The ISO interface enables the use of standard mounting kits
- The torque can be changed through a differentiated pre-tensioning of the spring. In this way, the MECAFRANCE spring return handle can be used for different nominal diameters
- The double stop on the inside avoids the risk of injury and, through its form stability, it ensures that the switching radius of 90 is adhered to
- A grease filling in the housing prevents spring corrosion
- The compact, closed housing rules out the possibility of any dirt foreign particles infiltrating, which could affect the function of the MECAFRANCE spring return handle
- It can easily be assembled on series RA, CA, ES and EA MECAFRANCE ball valves - even after valve is in service
- It can be used in either of the two switching positions, 'spring to close' or 'spring to open'
- The spring return handle must be operated fully open or fully close. Intermediate position can damage the seats and prevent proper operation of the spring return handle when returning to original position so they must therefore be avoided.

Spring return handle size DN15 - DN50

Stan- dard	Full port	ISO 5211	L2	ØD2	ØD3	D4	ØD6	H7	H8	Md (Nm)		Weight (kg)	Part		
										Close	Open		no.	Qty	Description
15	8-10	F05	200	35	50	M6	117	50	95	5	10	2.3	18	1	Lever
20	15	F05	200	35	50	M6	117	50	95	5	10	2.3	23	1	Lock washer
25	20	F05	200	35	50	M6	117	50	95	9	15	2.3	24	1	Stem nut
32	25	F05	250	35	50	M6	117	50	96	15	25	2.5	36	6	Screw
40	32	F05	250	35	50	M6	117	50	96	17	27	2.5	38	1	Spring
50	40	F05	250	35	50	M6	117	50	96	20	30	2.5	39	1	Lower part of housing
													40	1	Upper part of housing
													41	1	Control shaft

Pneumatic actuators

Top view

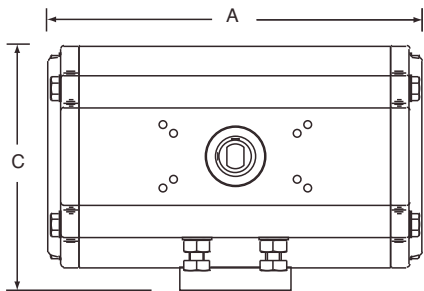

Side View

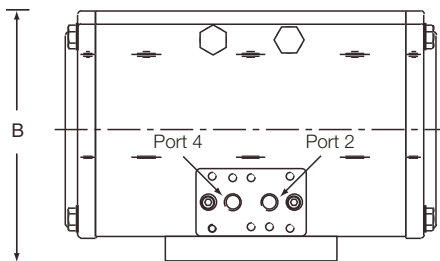

Bottom view

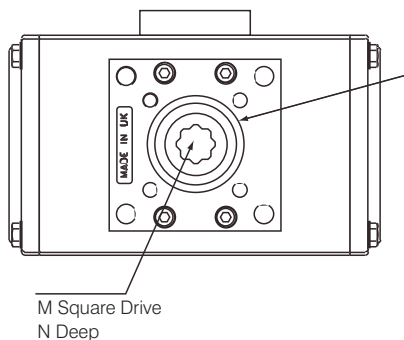

Front View

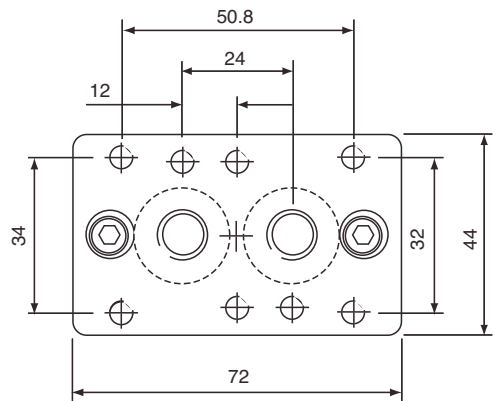
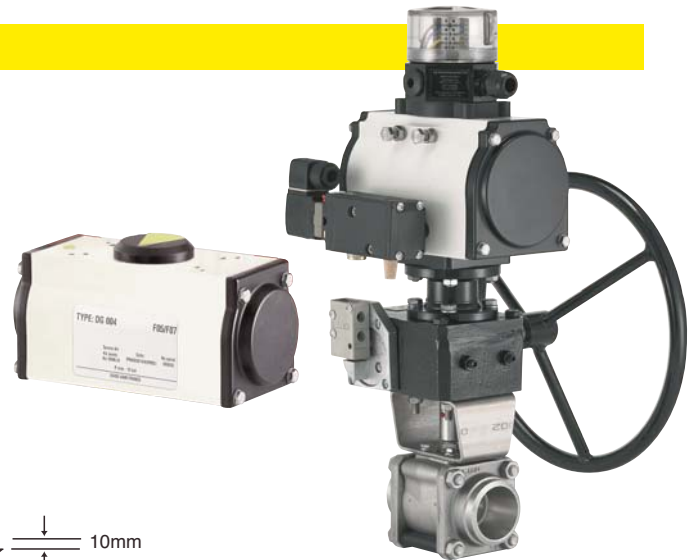
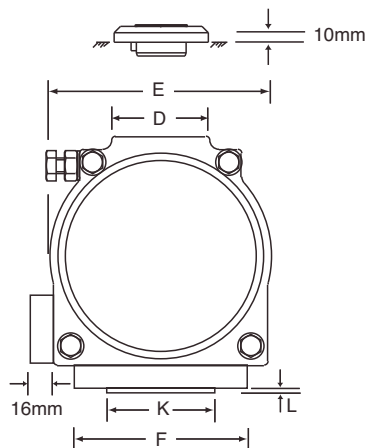

Technical details

- Conforming EN ISO 5211
- Double rack and pinion design
- Hard anodized aluminum body
- Adjustable travel stops
- Anti blow out drive pinion
- Detachable air connection plate
- Parallel and diagonal, double square (star) drive

- Action: Spring-to-Open, Spring-to-Close
- Each end 5° over travel, 10° under travel
- Body salt spray test according ISO 3768
- Air supply: between 2.75 and 8.3 bar

ATEX certified  II G D

Dimensions in mm

Actuator	Double Sq. drive (3)									Flange	Optional spigot		Hole details
Size	A	B	C	D	E	F	M	N	type	K	L	(Actuator to valve)	
002	155.8	83.4	86.8	56.8	70.8	67	14	16	F05	35	3	4xM6x9dp	
004	172	93.5	93	63.5	77	75	14	16	F05/F07	35/55	3	4xM6x9dp and 4xM8x12dp	
009	194.75	122	122	63.5	106	80	17	20	F05/F07	55	3	4xM6x9dp and 4xM8x12dp	
014	206	138	132.5	63.5	116.5	80	17	20	F07	55	3	4xM8x12dp	
025	242	163.5	157.25	63.5	139	112	22	24	F07/F10	55/70	3	4xM8x12dp and 4xM10x15dp	
037	285	184.5	173.95	72.3	163.5	116	27	30	F10/F12	70/85	3	4xM10x15dp and 4xM12x18dp	
045	333.5	200	185.8	75	174.6	116	27	30	F10/F12	70/85	3	4xM10x15dp and 4xM12x18dp	
070	394	230	216.6	88.9	205	127	27	30	F10/F12	85	3	4xM10x15dp and 4xM12x18dp	
088	417.5	254	234.75	98	221.5	150	36	38	F10/F14	100	4	4xM10x15dp and 4xM16x24dp	
180	481 (2)	282	266	130	250	190	46	48	F16	130	5	4xM20x25dp	

Serie SG

Sight glasses for visual checks of flows DN15 - DN150, butt weld, threaded, socket weld and double flanged version

Full Bore

SG CBS DN50



DN15 - DN150

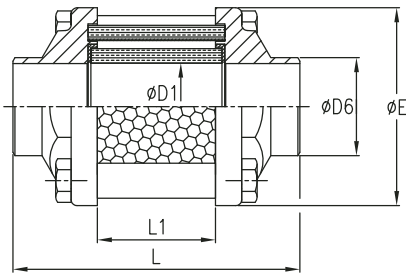

Butt weld: CBS

DN15 - DN150

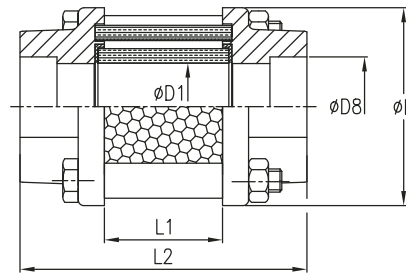

Socket weld: CBSW

DN15 - DN150

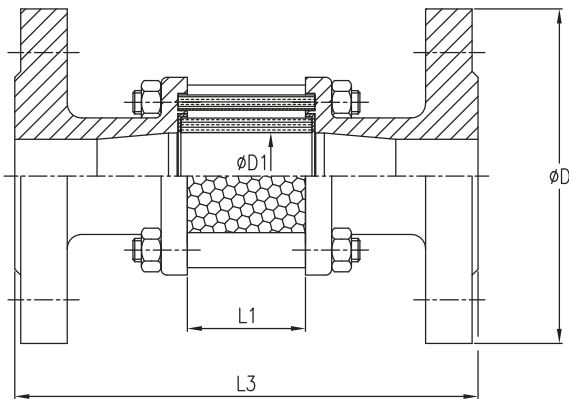

Flanged: CBF

DN15 - DN150

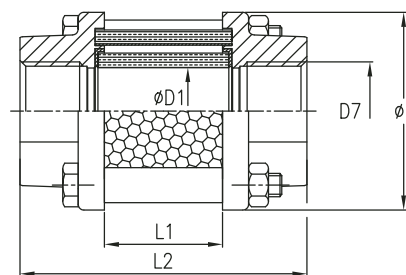

Threaded: CBG

Detailed technical information

- Pressure rating: PN16
- Full port version
- Stainless steel, other materials available on request
- PTFE gaskets
- Maximum temperature 200°C (up to 90° double safety version)
- Borosilicate glass for excellent chemical resistance
- Including protective screen for impact protection
- Butt weld ends (CBS) and socket welded ends (CBSW) can be welded directly to the pipes. No disassembly required
- Extremely low pressure losses

Dimensions in mm

DN	L	L2	L3	L1	$\varnothing E$	$\varnothing D$	$\varnothing D1$	$\varnothing D6$	D7	$\varnothing D8$
PN 16										
15	72.6	72.6	130	24.6	52	95	17	21.3	1/2"	21.8
20	85.4	85.4	150	31.4	60	105	21	26.9	3/4"	27.4
25	99.4	99.4	160	41.4	68	115	30	33.7	1"	34.2
32	110.4	110.4	180	48.4	76	140	40	42.4	1 1/4"	43
40	126.4	126.4	200	56.4	88	150	45	48.3	1 1/2"	49
50	142.6	160	230	71.4	143	165	56	60.3	2"	61.1
65	169.5	169.5	290	89	165	185	72 (CBS) 62 (CBF)	76.1	2 1/2"	77
80	169.5	179	310	88.9	165	200	82	88.9	3"	90
100	260	-	350	108	206	220	102	114.3	-	-
150	415	-	480	189	285	285	152	168.3	-	-

Manual operators

For series R



DN15 - DN65, low profile forged carbon steel handle

For series RA, CA, EA, EM and ES

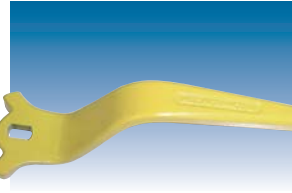

DN15 - DN65, high profile forged carbon steel handle

For series R

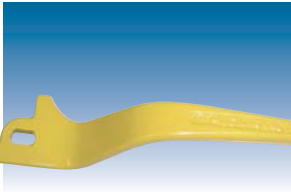

DN15 - DN65, high profile forged carbon steel handle

For series RA, CA, EA, EM and ES



DN15 - DN65, high profile forged stainless steel handle

For series R



DN15 - DN50, low profile pressed stainless steel handle

For series RA, CA, EA, EM and ES



DN15 - DN65, high profile stainless steel, lockable handle

For series R, RA, EA, EM and ES



DN80 - DN250, straight forged carbon steel handle
(Option: bolt-on pad lock provision)

For series R, RA, CA, EA, EM and ES



DN15 - DN50, stainless steel extension with bakelite balls, type RP

For series R, RA, CA, EA, EM and ES

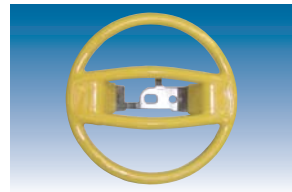

DN15 - DN50, round carbon steel handwheel

For series R, RA, CA, EA, EM and ES

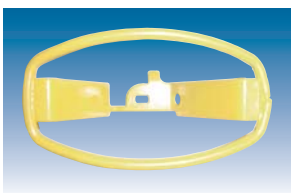

DN15 - DN50, oval carbon steel handwheel

For series R, RA, CA, EA, EM and ES

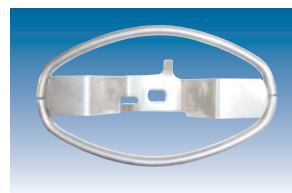

DN15 - DN50, oval stainless steel handwheel

Approvals and certification



Lloyds
Griss S.A.
2 Rue du Marais
80400 Ham

MECAFRANCE retains the following approvals and certificates

- ISO 9001 (Development, construction, production, mounting and service)
- Deliveries according AD 2000 – A4
- TA-Luft according VDI 2440
- Type approval for transportation according TÜ.AGG
Acceptance criteria: GGVE/RID, GGVS/ADR
Test criteria: TRT 024 und TRT 224
- Type approval according TÜ.VAR
Acceptance criteria: AD-Regelwerk, Druckbeh-VO, VbF/TRbF, Gas-HL-VO, WHG
Test criteria: DIN 3230 T5, DIN 3230 T6.
- Type approval for cryogenic ball valves according § 22 of the Pressure Vessel Code: DruckbehV - i.d.F. dated 21.04.1989 (BGBl. I S. 843)
- Fire-Safe according BS 6755: Part 2: 1987
For series R/RA 55/66:
DN15 - DN25 PN40 Report-No. E89288/5
DN25 - DN50 PN40 Report-No. E89288/1
DN65 - DN125 PN20/ANSI150 Report-No. E89288/6

- For series ES 55/66:
- DN15 - DN25 PN40/ANSI150 Report-No. E89288/2
 - DN32 - DN65 PN40/ANSI150 Report-No. E89288/3
 - DN80 - DN150 PN20/ANSI150 Report-No. E89288/4
- Type approval according Lloyd's Register for Shipping, Offshore, Industrial environment: Report-No. 98/20036
 - Stoomwezen for liquid gases: Report-No. M 0806
 - Anti-Static according VGF
 - Oxygen service according BAM VBG 62
 - Food and Drug Approval from the Department of Health and Human Services, USA
 - Re-stamping approval according TÜV-Südwest
 - Type approval Nr. 3131 for the Danish gas industry
 - DIN-GOST approval (on request)
 - CE-certification by Lloyds Register: CE0038 – Module H
 - ISO 14001
 - ISO 18001
 - OHSAS 18001



MECAFRANCE



MECAFRANCE reserves the right to change product designs and specifications without notice

Griss S.A.
2 Rue du Marais
80400 HAM
France
Tel : +33 3 23 81 43 00
Fax : +33 3 23 81 45 20
www.mecafrance-sa.com