

<b>Dimension range</b> DN 15 - 250	<b>PN</b> 16	<b>Temperature range</b> -10°C to +350°C	<b>Material</b> Ductile iron
---------------------------------------	-----------------	---	---------------------------------

## Range of application

Strainer for mechanical cleansing of warm-, hot- and cooling water, petroleum products, neutral fluids and steam.

## PMB.211 Strainer

Strainer AT 4029B, DN ... body made of ductile iron, PN 25/16, with differential pressure measurement sockets, flanges. Mesh width, 0,6 mm.

The differential outlets are located on the top.



AT 4028BE

## Quality assurance

### CE-marking

The strainers meet the requirements in PED 2014/68/EU, pressure equipment directive, according to Category I fluid group 2.

## Material specification

Pos	Component	AT 4029B
1	Body	Ductile iron EN-GJS-400-18LT
2	Strainer insert	Stainless steel 1.4301
3	Cover	Ductile iron EN-GJS-400-18LP
4	Cover gasket	Graphite CrNiSt
5	Cleaning plug / Diff.pressure plug	Steel C35E

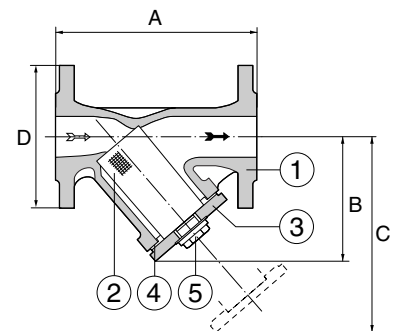

## Dimension and weight DN15-80

DN	15	20	25	32	40	50	65	80
A	130	150	160	180	200	230	290	310
B	90	100	115	135	150	155	175	205
C	135	150	180	215	240	250	285	330
D AT 4028B	95	105	115	140	150	165	185	200
D AT 4029B	95	105	115	140	150	165	185	200
Size: cleaning plug	G3/8	G3/8	G3/4	G3/4	G1	G1	G1	G1
Diff. pressure plug	G1/4	G1/4	G1/4	G1/4	G3/8	G3/8	G3/8	G3/8
Height strainer insert	56	68	82	98	114	119	134	149
Diam. strainer insert	23	28	36	42	50	61,5	78,5	89,5
Cover gasket, Dy	46	46	56	68	79	87	102	122
Cover gasket, Di	36	36	46	56	68	75	90	110
Weight AT 4028B	2,6	3,0	4,3	6,8	8,8	11,0	14,6	18,6
Weight AT 4029B	2,6	3,0	4,3	6,8	9,0	11,0	14,6	18,6

Dimension in mm, weight in kg

DN	100	125	150	200	250	300	350	400
A	350	400	480	600	730	850	980	1100
B	275	325	397	535	670	680	755	835
C	365	425	480	610	915	1110	1200	1320
D AT 4028B	220	250	285	340	405	460	520	580
D AT 4029B	220	250	285	340	405	**	**	**
Size cleaning plug	G11/2	G11/2	G11/2	G11/2	G11/2	G11/2	G11/2	G11/2
Diff. pressure plug	G3/8	G3/8	G3/8	G3/8	G3/8	G3/8	G3/8	G3/8
Height strainer insert	169	199	224	284	434	555	640	695
Diam. strainer insert	109,5	137,5	160	210	258	308	365	415
Cover gasket, Dy	135	170	195	270	300	375	425	475
Cover gasket, Di	120	151	175	245	275	350	390	440
Weight AT 4028B	27,0	38,5	54,5	110	165	285	373	461
Weight AT 4029B	27,0	38,5	54,5	102,7	165	285	**	**
Dimensions in mm, weight in kg								

## Function and design

Effectively catches the solid particles which are bigger than the strainer insert mesh when the media is passing through the cylindrical insert.

## Technical information

$K_{vs}$ -value applies to a clean strainer insert with a standard mesh width of 0,6 mm.

DN	15	20	25	32	40	50	65	80	100	125	150	200	250
$K_{vs}$	6,2	9,6	14,2	23,1	36,6	53,7	95,1	137,1	206,4	268,8	401	706	1229

### Pressure and temperature

Acc. to DIN EN 1092-2:1997 with the following max-values:

	AT 4029B, DN 15-50, PN 25	AT 4029B, DN 65-350, PN 16
<b>Min/Max working temperature</b>		<b>Max. working pressure.</b>
<b>°C</b>	<b>bar</b>	<b>bar</b>
-10	25	16
120	25	16
150	24,3	15,5
180		
200	23	14,7
230		
250	21,8	13,9
300	20	12,8
350	17,5	11,2

\*) NOTE! AT 4029B is in design PN 16, DN 65-250

## Fall of pressure

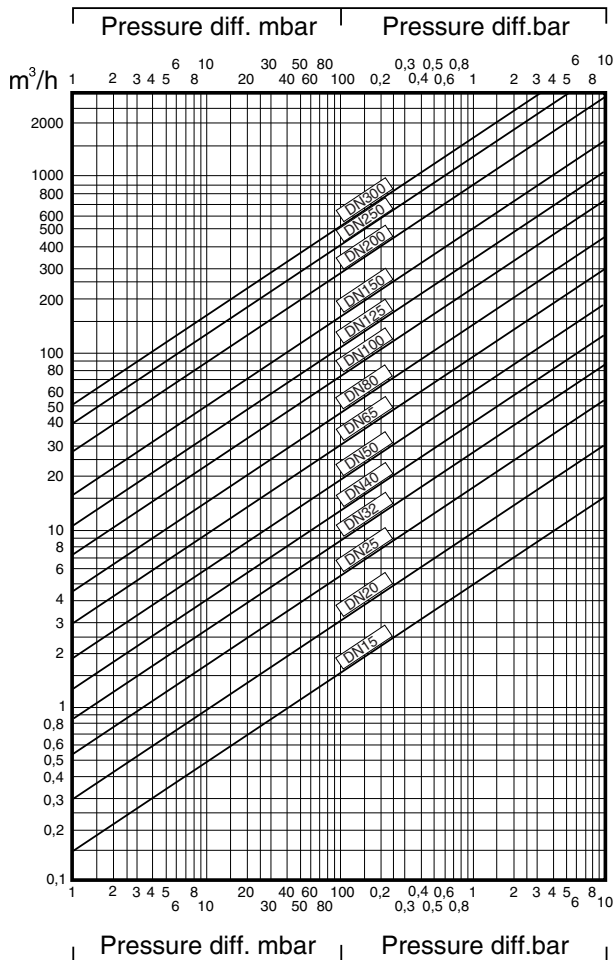

## Accessories and options

The insert gaskets standard mesh width is 0,6 mm. On request, the strainer can be provided with alternative mesh sizes, such as: 0,1, 0,25, 0,5, 1,0, 1,5, 2,0, 3,0, 5,0 and 8,0 mm.

Internal and external powder-coated epoxy is used for installations with hygiene requirements for water intended for human consumption or where there is a requirement for internal corrosion protection: AT 4028BE,

For differential pressure measurement across the filter, strainer DN 15-32 connection G 1/4. DN 40 and larger have connection G 3/8. See AT 1812.

For installation in cooling systems, the filters are available with external rust-preventing, according to system AT 1012.

## Installation

In a horizontal pipe the strainer should be mounted with the cover downwards. Not that the flow has to be according to the flow arrow. The strainer can be vertically mounted with a downwards flow.

A blow-out valve, e.g. AT 3535A or AT 3591, can be mounted instead of a clean-

out plug for an easier purge of the strainer insert.

Fig. no.	Flanges acc.to	
AT 4029B	DN 15-50	SS EN1092-PN 25
	DN 65-200	SS EN1092-PN 16

### Maintenance and spare parts

Highly increased pressure drop across the filter indicates that the strainer insert should be cleaned.

Strainer inserts AT 4028AF and cover gaskets AT 4028AL and AT 4028BL are available as spare parts.

### Marking

Manufacturer, DN, PN, material and flow arrow.

Marking in the body according to:

- AT 4028B, JL1040
- AT 4029B, JS1025

### How to order

Example: AT 4028B50		
DN	AT-no	RSK-no
15	4028B15	506 29 00
20	4028B20	506 29 01
25	4028B25	506 29 02
32	4028B32	506 29 03
40	4028B40	506 29 04
50	4028B50	506 29 05
65	4028B65	506 29 06
80	4028B80	506 29 07
100	4028B100	506 29 08
125	4028B125	506 29 09
150	4028B150	506 29 10
200	4028B200	506 29 11
250	4028B250	506 29 12
300	4028B300	506 29 13

<b>Example: Strainer AT 4029A50</b>		
<b>DN</b>	<b>Art.no.</b>	<b>RSK-no</b>
15	4029A15	506 29 14
20	4029A20	506 29 15
25	4029A25	506 29 16
32	4029A32	506 29 17
40	4029A40	506 29 18
50	4029A50	506 29 19
65	4029A65	506 29 20
80	4029A80	506 29 21
100	4029A100	506 29 22
125	4029A125	506 29 23
150	4029A150	506 29 24
200	4029A200	506 29 25
250	4029A250	506 29 26