

Air separator

AT 8050B

Dimension range G 3/8 - 1/2	PN 10	Temperature range 0 °C to 150 °C	Material Brass
---------------------------------------	-----------------	--	--------------------------

Range of application

For automatic air separation of heating and cooling systems where the fluid is water. Can be mounted in systems with a mix of water/glycol and water/ethanol, if control and oversight is increased. The valve should not be used in systems with a mix of water/salts. Can also be used in sun heating systems with an operational temperature up to 150 °C.

Program text

PSF.1412 Automatic air separator

Automatic air separator AT 8050B... in brass, PN10, 150 °C with dirt protection. Provided with a shut-off valve AT 3640-...

Quality assurance

Meets AFS 1994:4 §8 and should not be CE-marked. All extractors are density tested.

Material specification

1	Float chamber and upper part	brass 2.0402
2	Float	polymethylpentene PMP
3	Separation mechanism in leak proof performance	brass 2.0401

Dimensions and weight

Connection	A	B	C	Weight
G 3/8 external thread	98	48	73	0,30
G 1/2 external thread	98	48	73	0,35

Function and design

When air bubbles flow in to the float chamber the fluid level is decreased and the float sinks. When the float, which is connected to the separation mechanism through a downlink, has reached a certain level, a gap between seat and pin in the is formed in the separation valve. This makes it so that the air can flow out freely. When the float rises, caused by the water level rising again, the mechanism will close.

The separation valve's outer part has an external thread on which a cap is mounted. It has a soft seal that makes it so that the automatic separation can be shut off, when the cap is turned clockwise. The cap, which has slotted holes, must therefore be twisted two turns from closed position, for the automatic air separation to work.

Technical information

Can only be used to divert free gas bubbles in the system. Gas that is naturally dissolved in the fluid, because of high pressure or low temperature, can not be extracted. This gas can only be made available with vacuum degasser AT 8080S. See separate product sheet.

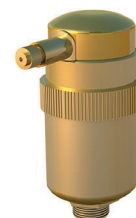

AT 8050B

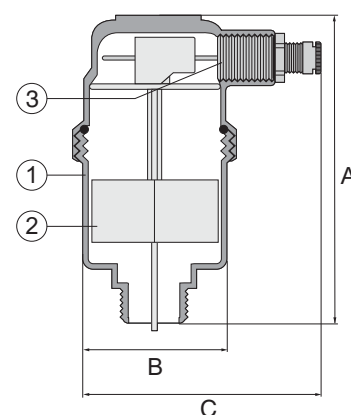

Installing

Mounted on high points or in other places where free air can be found. For correct function the separator should be mounted vertically with the connection downward. Note, during installation, that this must be reachable for control and cleaning. To really guarantee accessibility a ball valve like AT 3640 should be mounted before the separator as a shut off valve. During operational problems this valve can be closed and the air separator can be disassembled, cleaned, and reassembled without interfering with the rest of the facility.

Maintenance and accessories

For a secure operation and function the separator should be regularly controlled. With the recommended shut-off valve 3640 before the separator this will be done easily, without creating disturbances in the other parts of the system. Even if the automatic separator is of the highest quality, it's not possible to 100% guarantee a completely problem-free operation. The problem is usually caused by contaminations in the system or cooling. No spare parts is available. If operational problems occur, despite cleaning, the entire air separator needs to be replaced.

Marking

The valve is marked with dimension, max. operation pressure, max operation temperature, article number and the name of the manufacturer.

How to order

AT-no.	RSK-no.
8050B10	484 21 49
8050B15	484 21 50