

Globe Valve

with bellow seal

AT 1028B

Dimension range DN 15-100	PN 25	Temperature range -10 °C to +300 °C	Material Ductile iron
-------------------------------------	-----------------	---	---------------------------------

Range of application

Shut-off valve for:

- Steam
- Condensate
- Hot water
- Thermal oil

PSB.5 Globe Valve

Globe valve AT 1028B..., DN..., flanged connection. Ductile iron body with stainless steel bellows.

Quality assurance

Testing is carried out in accordance to EN 12266-1. Leakage class A applies to this type of valve.

CE-marking

The valves meet the requirements in AFS 2016:1 and 2014/68/EU (Pressure Equipment Directive).

Material specification

Pos	Component	Material
1	Body	Ductile iron EN-GJS400-18-LT
2	Bonnet	Ductile iron EN-GJS400-18-LT
3	Seat	Stainless steel 1.4006
4	Cone/globe	Stainless steel 1.4021
5	Bellow	Stainless steel 1.4571

Dimensions and weight

DN	15	20	25	32	40	50	65	80	100
A	130	150	160	180	200	230	290	310	350
B	178	178	193	201	224	228	270	295	321
C	125	125	125	125	150	150	175	200	250
Weight	3,2	3,9	4,6	6,5	9,0	11	15,8	20,5	35

Dimension in mm, weight in kg.

Function and design

With bellows that prevent the fluid from coming in contact with the stuffing box. This eliminates the risk of leakage from the stuffing box.

- External stem thread
- Position indicator, open/closed
- Non-rising handwheel

Technical information

Pressure and temperature

According to DIN EN 1092-2, with the following maximum values:

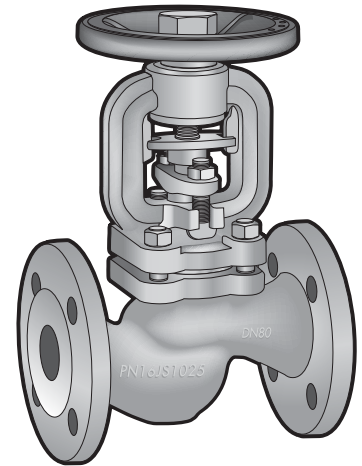

AT 1028B

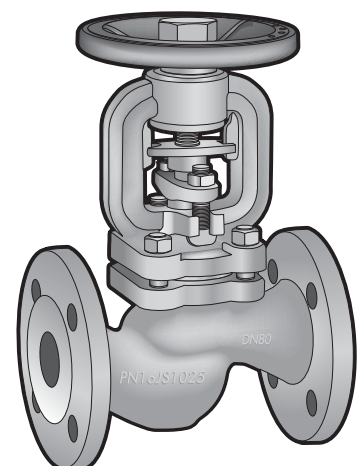

AT 1028B

Working pressure max. bar	Working temperature max. °C
25	-10
25	120
24,3	150
23	200
21,8	250
20	300
17,5	350

Pressure Drop

To calculate the pressure drop the following values are used:

DN	15	20	25	32	40	50	65	80	100
K _{vs}	5,9	7,4	13	18	30	41	79	115	181

Accessories and options

Larger dimensions on request.
Pressure class according to PN16.

Installation

Connections

Connection flanges according to SS 335 - PN25 . Can be mounted in any position except with handwheel pointing downwards.
Vibrations in the piping system should be avoided. The system should be flushed before startup.

Maintenance and spare parts

The valve is practically maintenance free.

Marking

Manufacturer, DN, PN, CE, material and flow arrow.

How to order

Example: AT 1028B50	
AT 1028B	50
Fig. No.	DN
RSK-number, see the RSK-register	