

Ball Valve

All-welded

AT 3590S, 3591S

Internet_Variants

Dimension range	PN	Temperature range	Material
DN 10-50	40	-20 °C up to 204°C	Steel
DN65-400	25		

Range of Application

As shut-off valve for warm and hot water systems, compressed air and gases, fluid group 2.

PSB.1 Ball valves

DN 10-150 with lever; Ball valve AT 3590S, DN ... Body of steel with weld ends. With longstem neck adapted for insulation.

For DN 200-400 with gear; Ball valve AT 3590V, DN ... Body of steel with weld ends. With longstem neck adapted for insulation.

Ball valve AT 3591 with lever, DN ... Body of steel with one weld end and one internal thread connection. With longstem neck adapted for insulation.



AT 3590S

Quality Assurance

CE-märking

District heating 25bar:

Ventiler DN 10 t.o.m. 40 acc. PED 2014/68/EU. Fluids group 2.

Ventiler DN 50 t.o.m. 125 acc. PED 2014/68/EU. Category I, fluids group 2.

Ventiler DN 150 och 200 acc. PED 2014/68/EU. Category II, fluids group 2.

Ventiler DN 250 t.o.m. 400 acc. PED 2014/68/EU. Category III, fluids group 2.

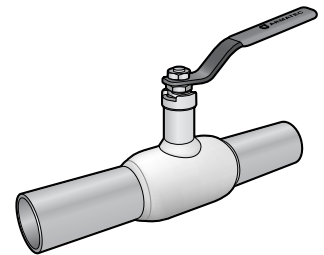

AT 3590

Material Specification

1	Body/weld ends	steel	1.0345
2	Ball	stainless steel	1.4301
3	Seat rings	PTFE	
4	Stem	stainless steel	1.4028
5	Stem gasket	PTFE	

Dimension and Weight

Ansl.		10	15	20	25	32	40	50	65	80
A	AT 3590S	230	230	230	230	260	260	300	300	300
A	AT 3591	125	165	175	185	200	220	245	-	-
B (H)	AT 359xS	119	119	134	138	142	145	151	158	215
B	AT 3590V	-	-	-	-	-	-	-	-	-
C		-	-	-	-	-	-	-	-	-
E	AT 3590	-	21,3	26,9	33,7	42,4	48,3	60,3	76,1	88,9
E	AT 3590V	-	-	-	-	-	-	-	-	-
ISO 5211	AT 359x		F05	F05	F05	F05	F05	F07	F07	F10
ISO 5211 Diagonal square	AT 359x		11	11	11	11	11	11	14	19
Req torque (Nm)	AT 359x		3	4	7	16	25	48	68	93
Vikt	AT 3590	-	0,6	1	1	1,4	2	2,9	4,2	9

Measurements in mm, weight i kg.

Ball Valve

All-welded

AT 3590S, 3591S

Dimension and Weight

Ansl.		100	125	150	200	250	300	350	400	450	500	600	
A	AT 3590	325	325	350	390	520	620	850	900	950	950		1150
B (H)	AT 3590	223	252	290	312	349	352	382	382	506	506		600
C		-	-	-	-	-	-	-	-	-	-	-	-
D	AT 3590	114,	139,	168,	219,		323,	355,					
E	AT 3590V	3	7	3	1	273	9	6					406,4
ISO 5211	AT 359x	-	-	210	240	285	360	450					550
ISO 5211 Diagonal square	AT 359x	F10	F10	F12	F12	F16	F16	F16	F16	F25	F25	F25	
Req torque (Nm)	AT 359x	19	22	27	27	27	36	36	36	46	46	46	
Weight	AT 3590					203	197	270	270				
		173	331	505	931	3	1	7	7	3213 (16bar)	3213 (16bar)	4782 (16bar)	
		10	17	20	40	71	170	-					

Mått i mm, vikt i kg.

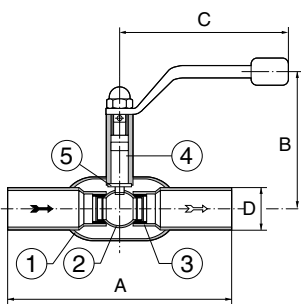

Function and Design

Fully welded pipe construction with weld ends, adapted for direct welding into pipe systems. The ball's reduced bore. The ball is clamped between two seat rings of PTFE. The valve is supplied as standard with high longstem neck for insulation. The stem top is thus always visible and possible to inspect. ISO top according to ISO5211.

Technical Information

Fig. no	Connection	Max. working pressure
AT 3590S	DN15-50	40
	DN65-400	25
	DN15-50	40
AT 3591S		

Kv-value

Connection	15	20	25	32	40	50	65	80	100	125	150	200	250
Kvs	6	15	30	41	72	104	160	282	452	696	1104	1521	2784

Kv-value

Connection	300	350	400	450	500	600
Kvs	4641	7853	7673	14677	14305	22353

Torque at 25bar differential pressure

Ansl.	15	20	25	32	40	50	65	80	100	125	150	200	250	300
Nm	3	4	7	16	25	48	68	93	173	331	505	931	2033	1971

Torque at differential 25 bar

Connection	25	32	40	50	65	80	100
Nm	7	16	25	48	47	93	173

Rätten till ändringar utan föregående meddelande förbehålls.
Armatec ansvarar inte för eventuella tryckfel eller missförstånd.
Dokumentet får kopieras endast i sin helhet.

Ball Valve

All-welded

AT 3590S, 3591S

Installation

The valve can be mounted in any position independent of the flow direction. Welding should be done with the valve in full open position. Note, in the case of gas welding the valve must be cooled down to protect the seat rings from damage.

Accessories and Options

Can be fitted with different types of actuators and limit switches.

Maintenance and Spare parts

The valve is practically maintenance free. However, there should be regular monitoring and maneuvering control for safe operation and function.

Marking

DN, PS, materials of pressure parts, year and month of manufacture, AT-No and CE-marking shown on the identification label.

How to order

Connection	With weld ends		With weld ends		With weld ends/internal thread	
	AT-no	RSK-no	Worm gear	RSK-no	AT-no	RSK-no
10	3590-10	451 27 61			3591-10	451 65 10
15	-15	451 27 62			-15	451 65 11
20	-20	451 27 63			-20	451 65 12
25	-25	451 27 64			-25	451 65 13
32	-32	451 27 65			-32	451 65 15
40	-40	451 27 66				
50	-50	451 27 67				
65	-65	451 27 68				
80	-80	451 27 69				
100	-100	451 27 70				
125	-125	451 27 71				
150	-150	451 27 72	3590V150	451 27 76		
200			V200	451 27 73		
250			V250	451 27 74		
300			V300	451 27 75		
350			V350			
400			V400			